



Installation Instructions



Tigertop™











Includes 1-Piece Full Soft Door

Vehicle Application

- Jeep CJ7
1976 – 1986
Part Number: 51408

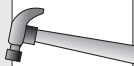
www.Bestop.com - We're here to help! Visit our web site and click on ["Ask a Question"](#). Click here for more [Jeep Accessories by Bestop](#).

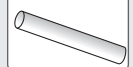
INSTALLATION TIME	SKILL LEVEL
 <p>3 Hours</p>	 <p>3 - Moderately Difficult</p>

TOOLS			
 Power Drill <small>3/32", 1/8", 7/32", 5/32" and 3/8" Bits</small>	 Center Punch	 Pencil	 Tape Measure <small>10'</small>
 Wrench <small>7/16"</small>	 Phillips Screwdriver	 Hammer	 Adjustable Wrench
 Utility Knife	 Chalk	 Safety Glasses	



 **CAUTION** Safety glasses should be worn at all times while installing this product.

Installation Tips
 Before you begin installing this assembly, read all instructions thoroughly.

For a smooth fit:
 For ease in installation, the product should be installed at temperatures above 72° F. Below this temperature, the fabric may contract an inch or more, making it difficult to fit to the vehicle. It is normal for fabric to contract and wrinkle when stored in the shipping carton. Within a few days after the installation, the fabric will relax and the wrinkles will disappear.

 **WARNING** This product is designed primarily to enhance the appearance of the vehicle and to shield the occupants from ordinary weather conditions. Do not rely in any way on the components of this product to contain occupants within the vehicle, or to protect against injury or death in the event of an accident. This product will not protect the occupants from falling objects. Never operate the vehicle in excess of manufacturer's specifications.

WEAR SEAT BELTS AT ALL TIMES

Read and follow, precisely, all installation instructions provided when installing product. Failure to do so may result in a poor fit and could place occupants of the vehicle in a potentially dangerous situation.

Tigertop™ – Installation Instructions

Top Fabric	Qty - 1
Door, Right	Qty - 1
Door, Left	Qty - 1
Buckle Straps	Qty - 2

Parts List and Hardware Identification

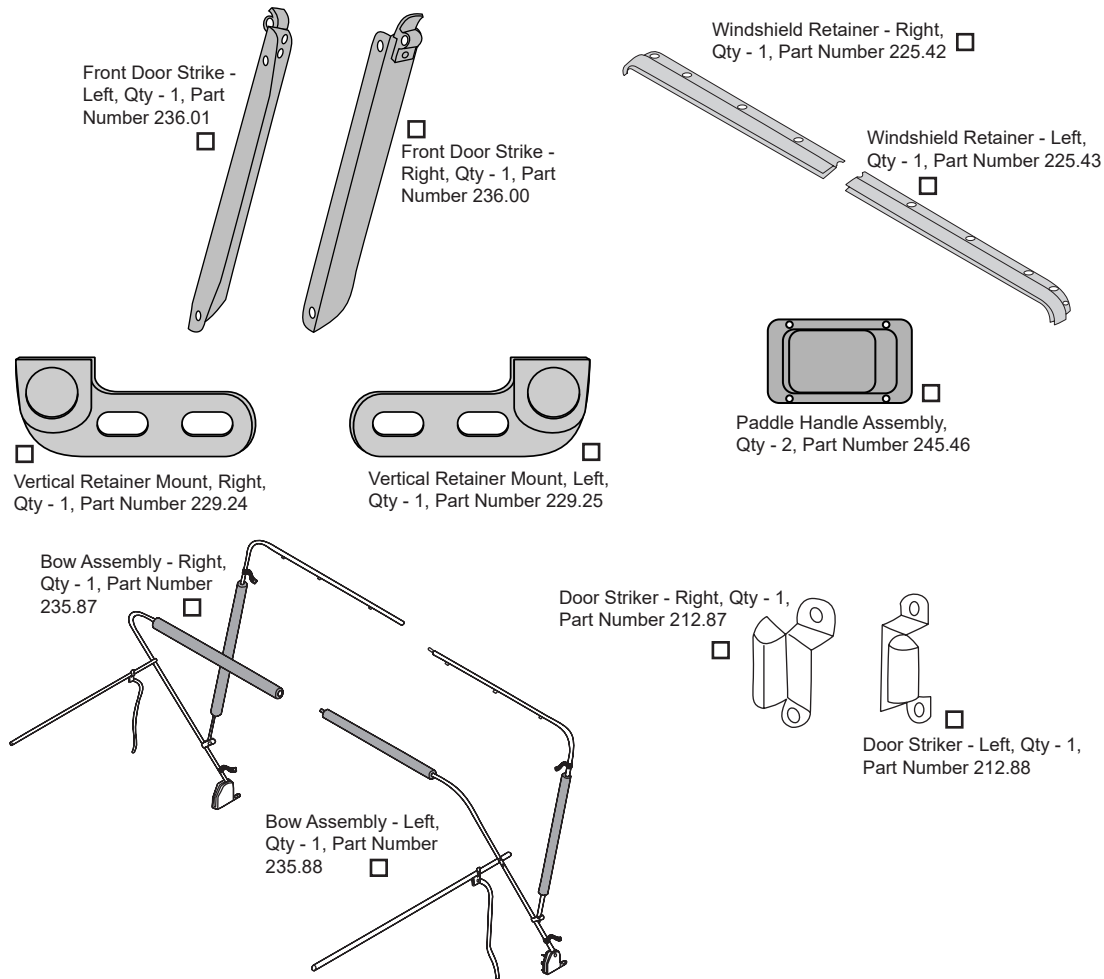

#8 x 1/2" Pan Head Washer Screw - Black, Qty - 11, Part Number 200.48

#10-24 Truss Head Machine Screw - Black, Qty - 16, Part Number 195.92

#10 x 1/2" Oval Head Screw, Part Number 155.49, Qty - 4

#6 x 3/8" Sheet Metal Screw, Qty - 27, Part Number 9.69

Body Stud, Qty - 27, Part Number 9.68

5/16" Black Washer, Qty - 8, Part Number 233.04

#10-24 Locknut, Qty - 16, Part Number 195.93

5/16-18 Tapping Plate, Qty - 8, Part Number 200.50

5/16-18 x 1" Phillips Head Bolt, Qty - 8, Part Number 236.20

Footman Loop, Qty - 2, Part Number 272.29

Because of Generic Packaging, extra parts may be included.

Tigertop™ – Installation Instructions



WARNING

Improper windshield adjustment will result in poor fitting top and

doors, causing looseness or undue strain on the top.

CJ7 Windshield Measurement

Before installing the top, check the windshield measurement. The distance from the top lip of the windshield to the top outer edge of the body must be 75 1/8" on both sides of the vehicle. Measure from 6" inside the doors.

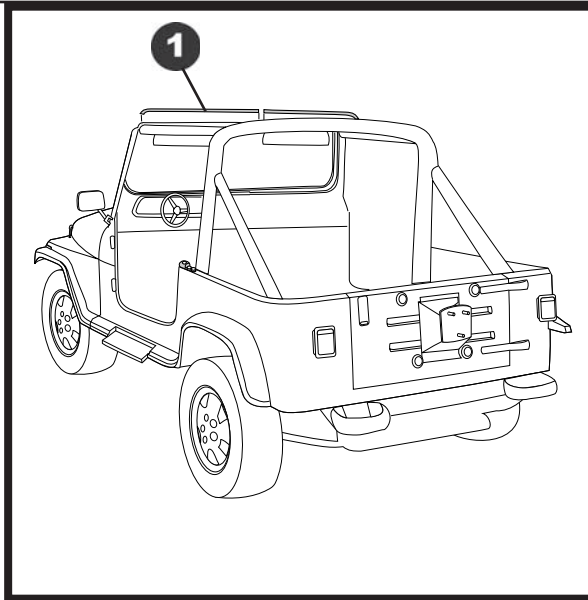
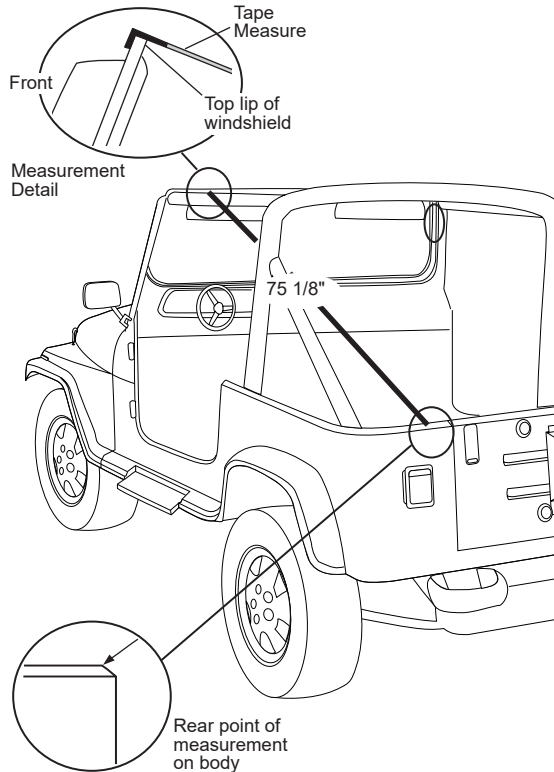

WARNING

A loose Windshield Retainer may allow the top to disengage from the

windshield, causing damage to the top and possible injury to the occupants of the vehicle.

Make certain that the Windshield Retainer is securely fastened to the windshield during installation and at all other times by checking the tightness of the mounting screws every three months.

Do not use any drill size other than 1/8". Failure to use the correct size may cause the Windshield Retainer to loosen.

1 Install Windshield Retainer

Install Windshield Retainer on top of windshield frame. Use retainer pieces as templates to mark, center punch and drill eleven 1/8" holes. Install with eleven #8 x 1/2" Phillips Head Screws.

CJ7 Windshield Adjustment: If necessary, loosen the two screws in the Windshield Clamps at the base of the windshield on each side of the vehicle. Adjust the windshield forward or back, use a shim if needed to position the windshield, and tighten the screws.

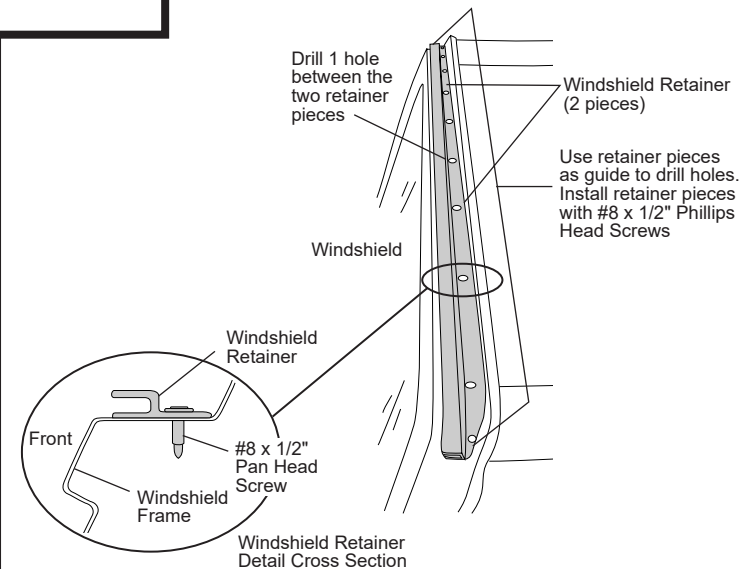
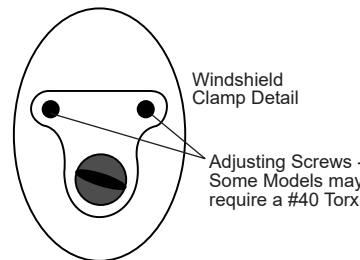

Tigertop™ – Installation Instructions

CAUTION When drilling in the top edge of the vehicle body, check underneath for wiring for the rear lights. Pull the wiring out of the way before drilling.

2 Install Vertical Retainer Mount

Measure 42 1/4" and 43 1/4" along the top edge of the body from the outside rear corner. Mark these locations with a pencil on the top edge of the body. Center punch the marked locations and use a 5/32" drill bit to drill a pilot hole. Then drill a 3/8" hole at each location. Install the Vertical Retainer Mounts with two 5/16"-18 x 1" Phillips Head Bolts, two 5/16" Washers and two 5/16"-18 Tapping Plates. Repeat this procedure on the opposite side of the vehicle. The mounts may need to be loosened to adjust the Vertical Retainer position.

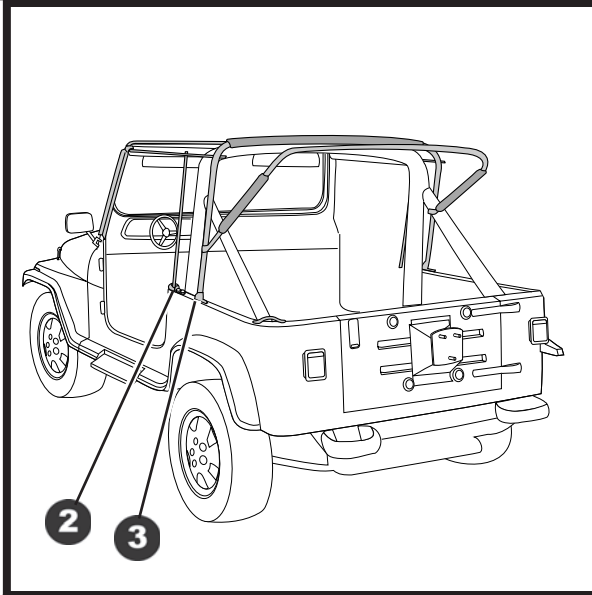
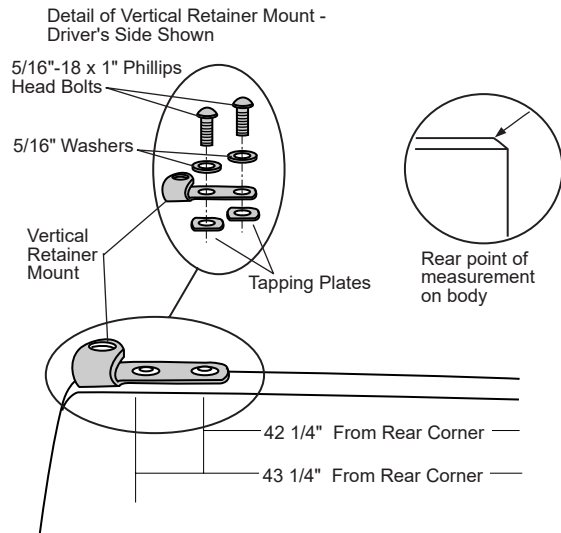

CAUTION When drilling in the top edge of the vehicle body, check underneath for wiring for the rear lights. Pull the wiring out of the way before drilling.

3 Install Bow Assembly

Measure 29 1/4" and 31 1/4" along the top edge of the body from the rear corner. Mark these locations with a pencil. Center punch and drill a 3/8" hole in each location. Secure the front hole in the Bow Mount with a 5/16"-18 x 1" Phillips Head Bolt, a 5/16" Washer and a 5/16" Tapping Plate. Once the front hole is secure, raise the bow assembly up and secure the rear hole in the mount.

NOTE It may be helpful to have two people so that one person can support the bow halves while they are installed.

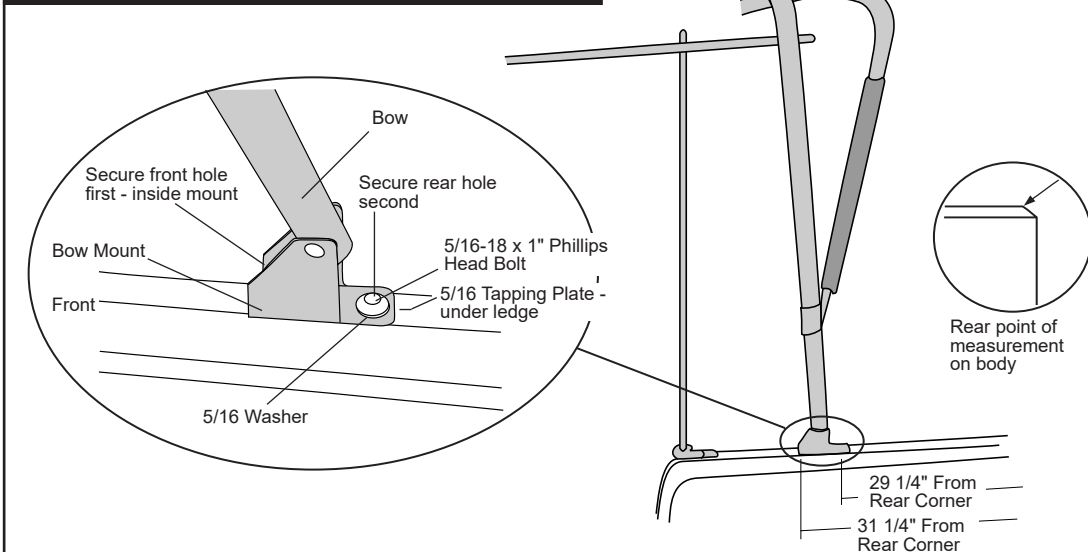

Tigertop™ – Installation Instructions



CAUTION

When drilling in the top edge of the vehicle body, check underneath for wiring for the rear lights. Pull the wiring out of the way before drilling.

4 Install Footman Loops

Install the Footman Loops on the rear corners of the vehicle. Center the loops over the Phillips Head Bolt on the top, rear corner on each side of the vehicle. Use the loop as a template to mark, center punch and drill two 5/32" holes. Install the Footman Loop with two #10 x 1/2" Oval Head Phillips Screws. Do this on both sides of the vehicle.

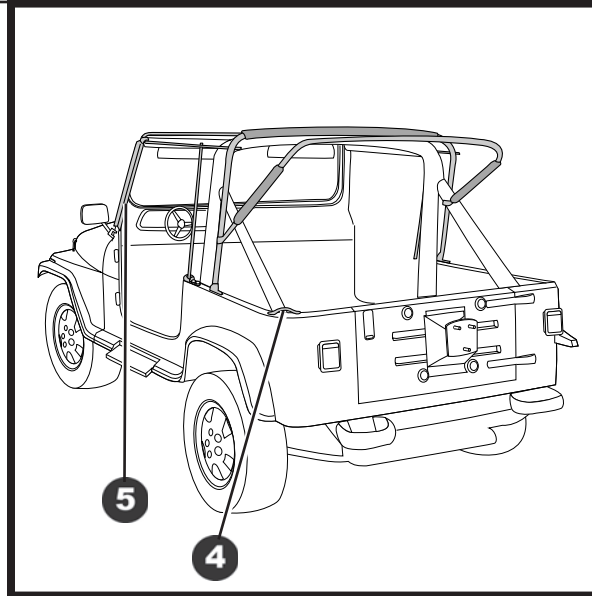
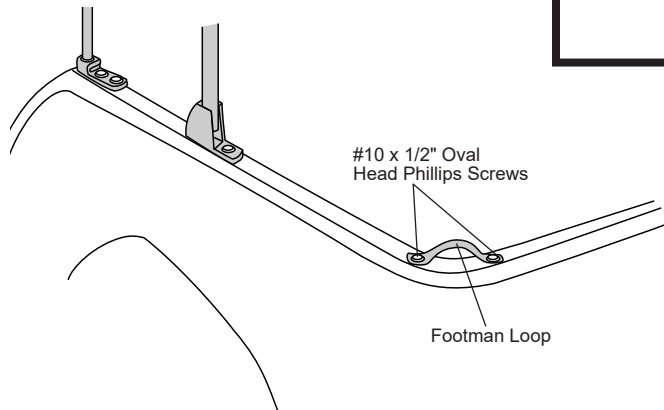

5 Install Front Door Strikes

Place the Front Door Strike on the outside flange of the windshield and flush with the bottom of the flange. Use the Front Door Strike as a template to mark, center punch and drill two 7/32" holes in the windshield frame flange. Install the Front Door Strike with two #10-24 Truss Head Machine Screws and two #10-24 Locknuts. Repeat this on the opposite side of the vehicle.

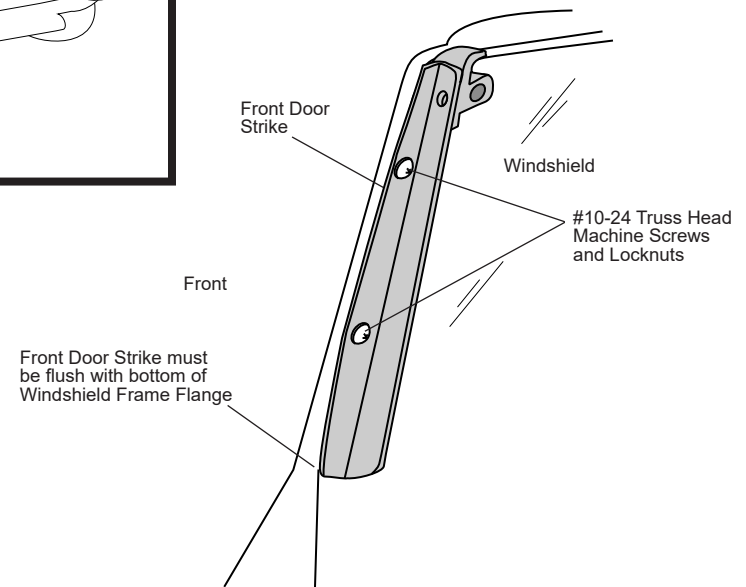

Tigertop™ – Installation Instructions

6 Secure Bow Assembly

With the bow halves lying on the rear of the vehicle body, start the male end of one assembly into the female end of the other assembly until they snap together. Slide the foam halves together over the joint in the bow until they touch. Rotate the Front Bow forward and slip the Vertical Rods into the Vertical Retainer Mounts. Insert the Horizontal Rod into the plastic assembly on the Front Door Striker.

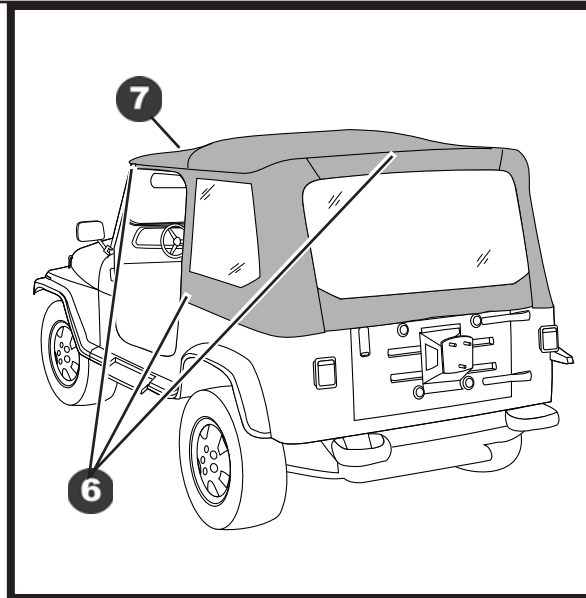
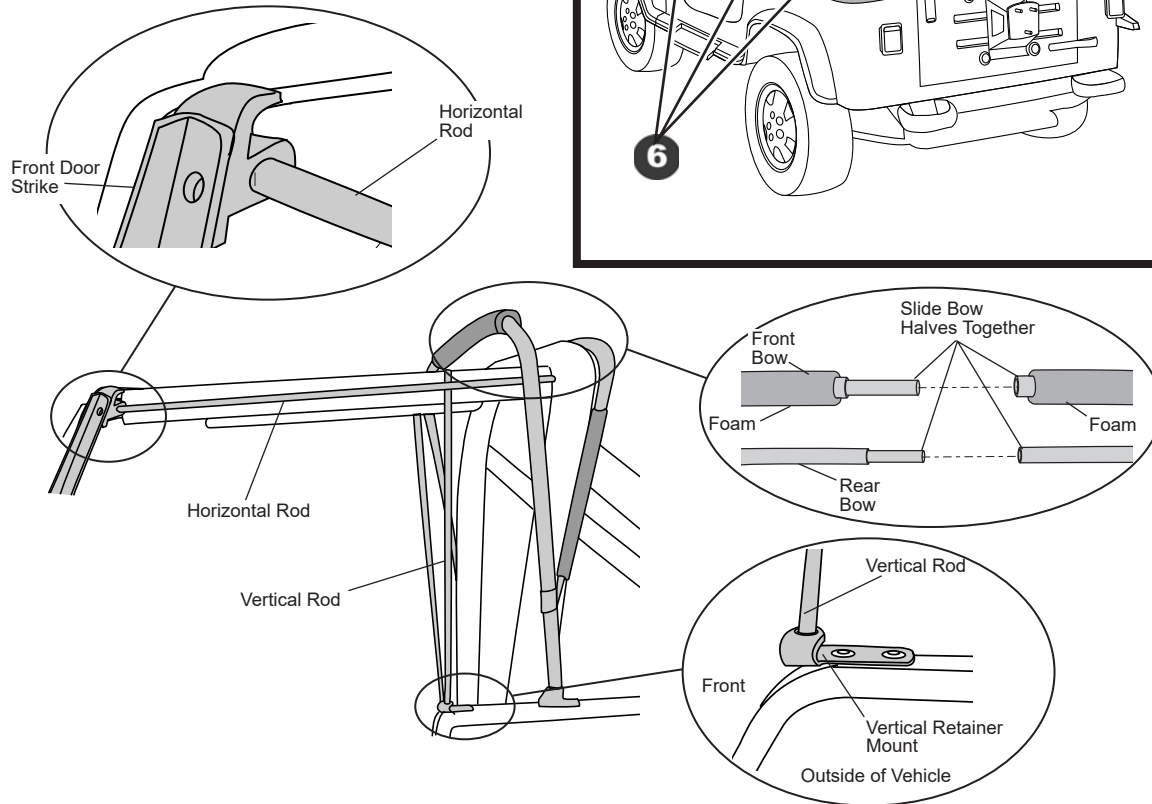

7 Install Top on Vehicle

Locate the top and orient it on the vehicle. Drape the top over the bows and insert the plastic strip along the front edge of the top into windshield retainer. Center the front of the deck on the vehicle so that it is an equal distance from the top of the windshield flange on both sides. Locate the Buckle Straps in the parts kit. Wrap each strap around the corners of the Rear Bow and snap the straps to themselves. These straps will hold down the Rear Bow when the Rear Curtain and Side Panels are rolled up.

NOTE For best possible installation, check to make sure that the soft top is perfectly centered on the vehicle.

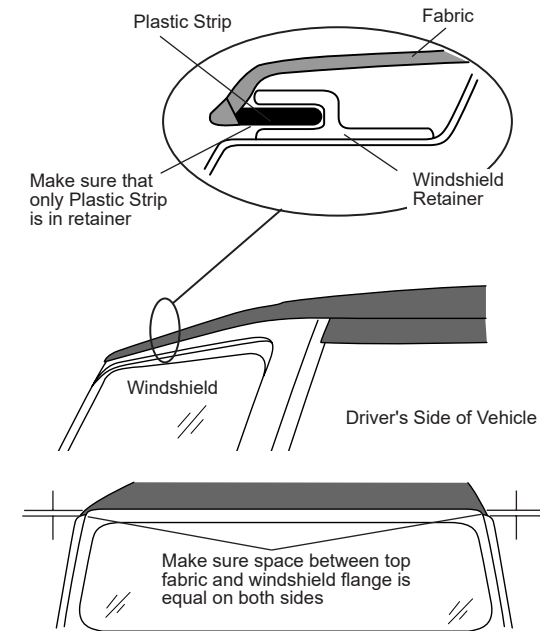

Tigertop™ – Installation Instructions

8 Snap Top to Rear Bow

Snap the flaps to the six studs on the rear bow.

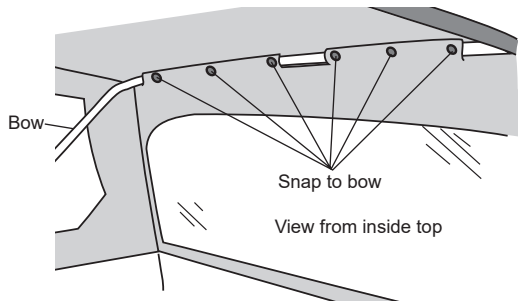

NOTE IMPORTANT: The following steps are extremely important to the fit of the top and will require two people.

Make sure that the top is as warm as possible before continuing with the installation.

9 Adjust Tension on Top

Close the zippers on the Rear Curtain. Slide the Rear Bow up on the Front Bow and insert the small bent tab in the bottom of the four holes in the Front Bow.

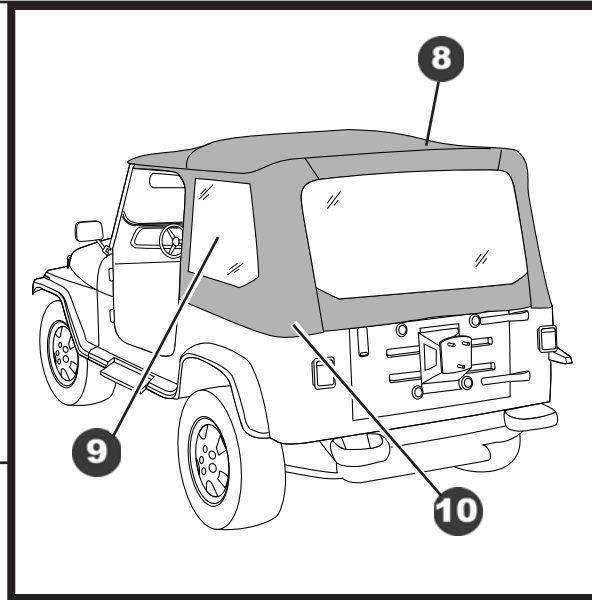
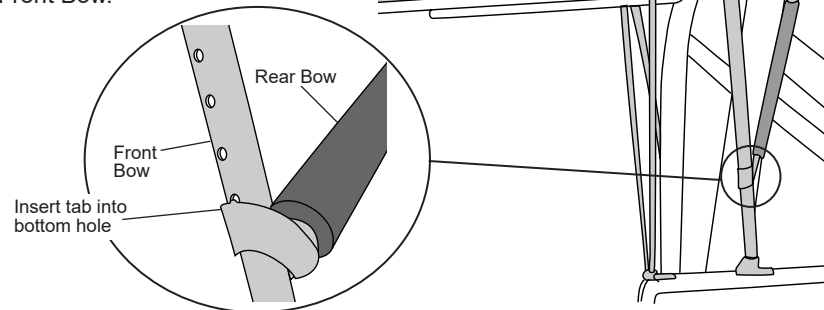

10 Install Rear Corner Snaps

Rub chalk on the snaps on the inside of the top to mark the stud locations. Have one person pull down on the Rear Bow while the other person pulls the fabric down and to the rear to locate the Rear Corner Studs. The studs should be located 1/2" - 3/4" below the bottom of the bevel.

When you are satisfied with the tightness of the top, press the snaps against the body. The chalk will leave marks for the Body Stud locations. Center punch the marks and drill a 3/32" hole at each marked location. Install a Body Stud with a #6 x 3/8" Sheet Metal Screw at each location. Snap the top to the Rear Corner Studs.

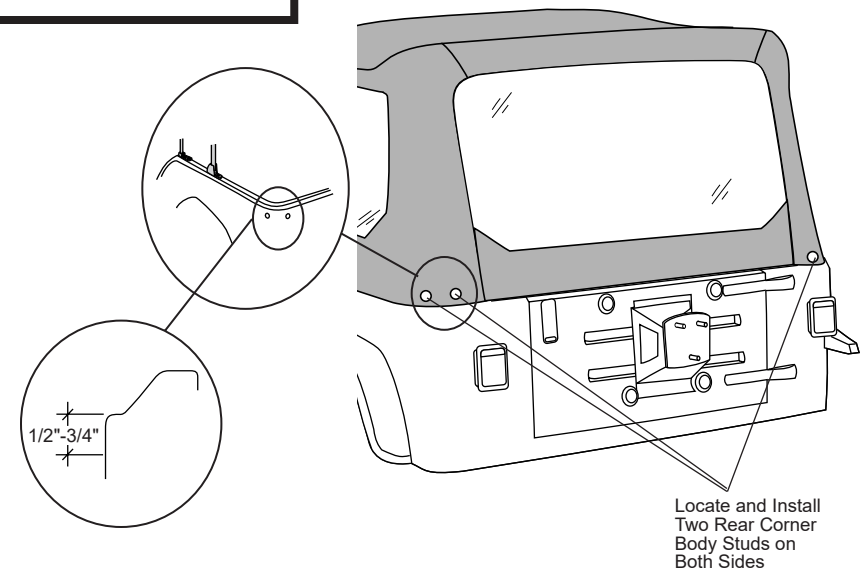

Locate and Install Two Rear Corner Body Studs on Both Sides

Tigertop™ – Installation Instructions

11 Raise the Rear Bow

Slide the Rear Bow up on the Front Bow and insert the small bent tab into the third hole from the bottom in the Front Bow.

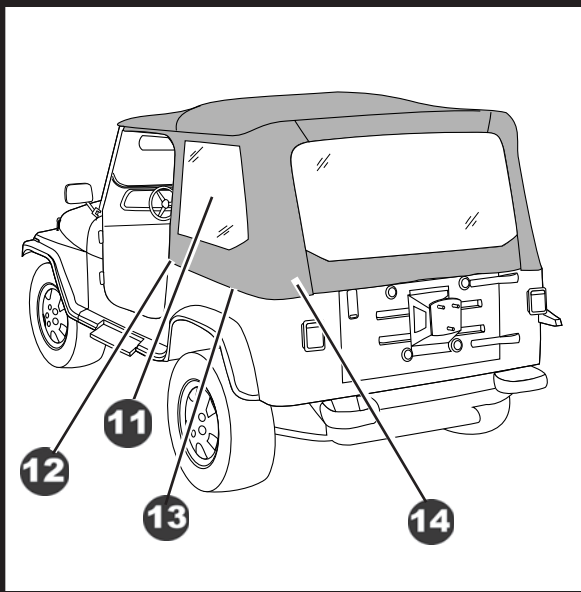
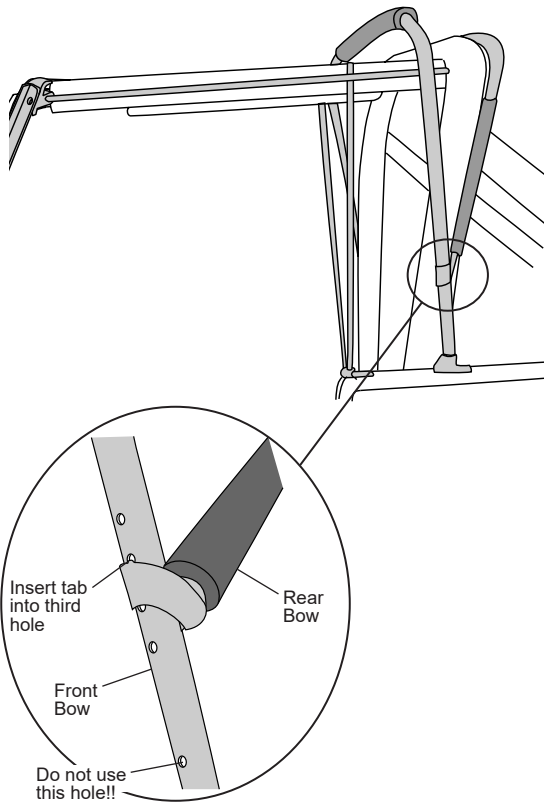

12 Install Front Snaps

At the front of the Side Panel, pull the fabric down and forward to eliminate wrinkles. Mark, center punch and install a Body Stud as before 1/2" -3/4" below the bottom of the bevel. Do this on both sides of the vehicle.

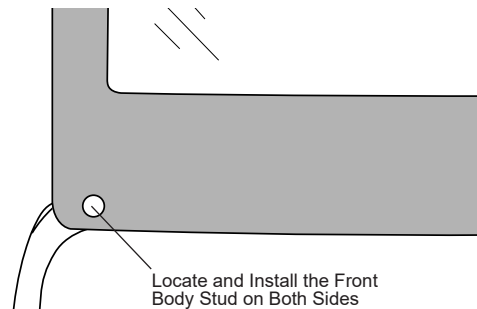

13 Install Remaining Snaps

Install the remaining Body Studs on the Side Panels and the Tailgate. Alternate from side to side as you install the studs. Snap the top to each new stud to keep the tension on the top spread evenly.

14 Secure Buckle Straps

Thread the Buckle Straps, on the Rear Bow, through the Footman Loops. Pull them up and thread them through the buckle.

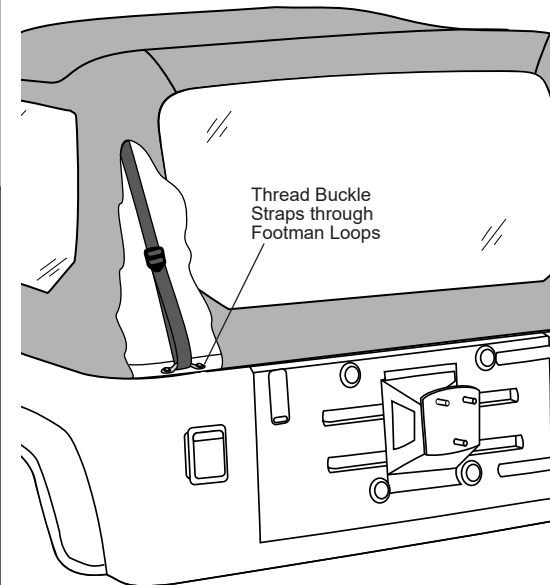

Tigertop™ – Installation Instructions

15 Secure Front of Side Curtain

Wrap fabric flap on the front of the side curtain around the Vertical Rod (not the front bow) and fasten the hook and loop strips to each other.

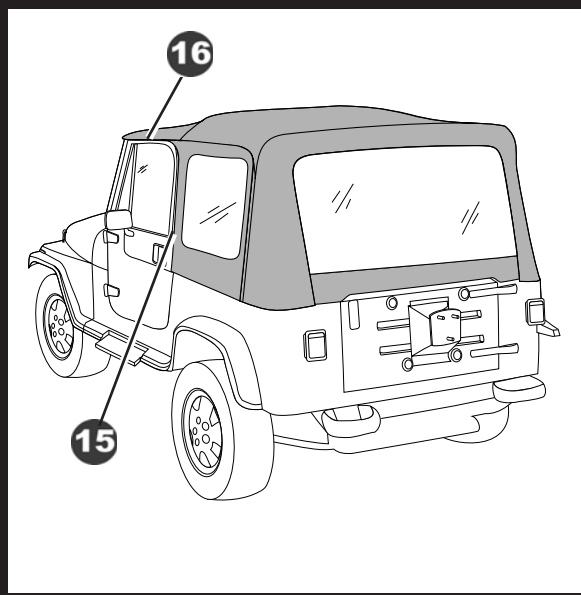
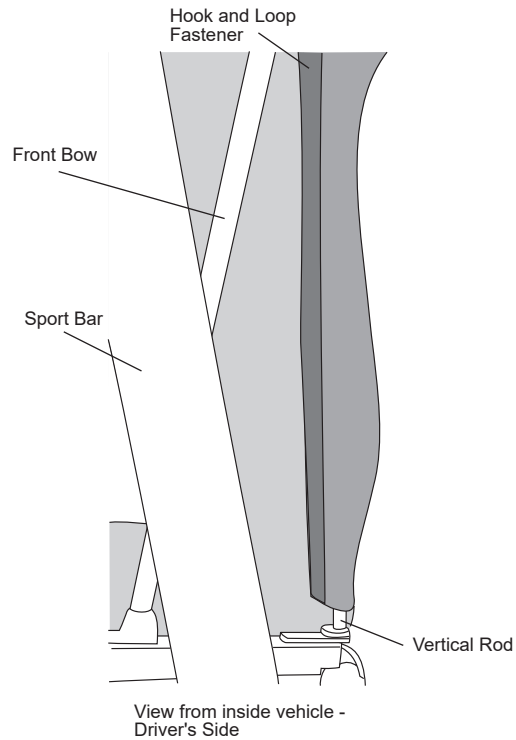

16 Secure Door Flaps

Wrap the flap, sewn to the top above each door, around the Horizontal Rod and fasten the hook and loop strips to each other.

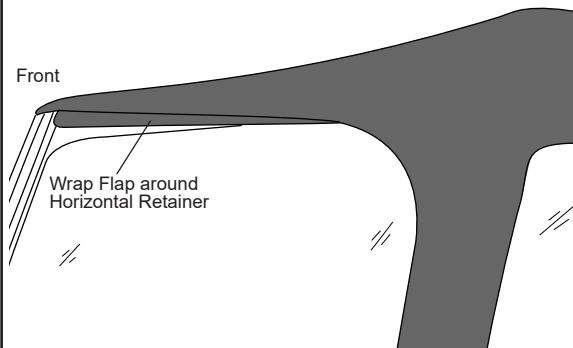

Tigertop™ – Installation Instructions



WARNING

The doors in this product are designed only for protection against the elements. Do not rely on the doors to contain occupants within the vehicle or to protect against injury during an accident. Door handles are only designed to aid in door closure. Door and handle will not support a person's weight.

17 Install Paddle Handle on Door

Locate the pre-cut "X" in the door panel where the Paddle Handle will fit into the mounting plate on the door frame. Fold the pre-cut fabric back and insert the Paddle Handle into the mounting plate so that the latch mechanism is inside of the vehicle and the latch bolt is toward the rear of the door. Align the four holes in the Paddle Handle Assembly with the four holes in the mounting plate. Use a pointed tool to punch four holes in the fabric to match the holes in the Paddle Handle and the mounting plate. Insert four #10-24 Truss Head Machine Screws from the outside and secure them with #10-24 Locknuts. Do not tighten the screws until all four are in place. Trim the excess fabric around the Paddle Handle. Repeat for both doors.

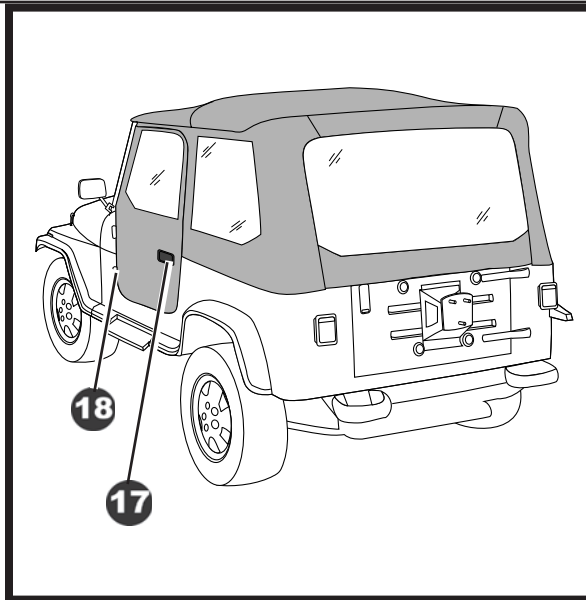
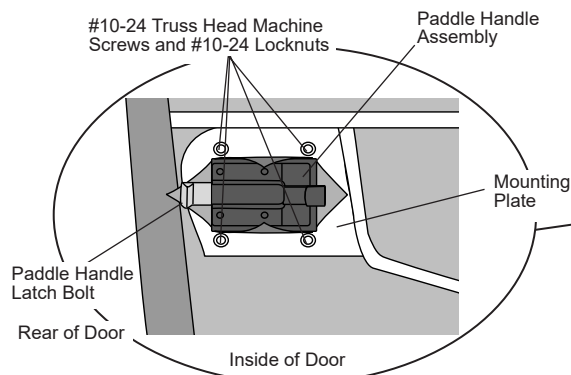

18 Install Doors on Vehicle

Hold the door straight out from the vehicle with the hinge pins over the body hinges. Lower the pins into the hinges. Make sure that the pins are fully inserted into the body hinges. Close the door and check all sides to make sure that it fits properly against the body.

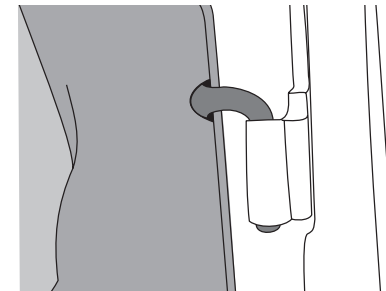

Tigertop™ – Installation Instructions

19 Install Door Strikers on Vehicle

Close the door against the body and place the Door Striker behind the Paddle Handle Latch with the flat surface to the inside of the vehicle and with the raised end toward the top. Mark, center punch and drill two 7/32" holes. Install the Door Striker with two #10-24 Truss Head Machine Screws and two #10-24 Locknuts. The Door Striker may be adjusted in or out until you are satisfied with the way the door shuts and opens. Repeat on both sides of the vehicle.

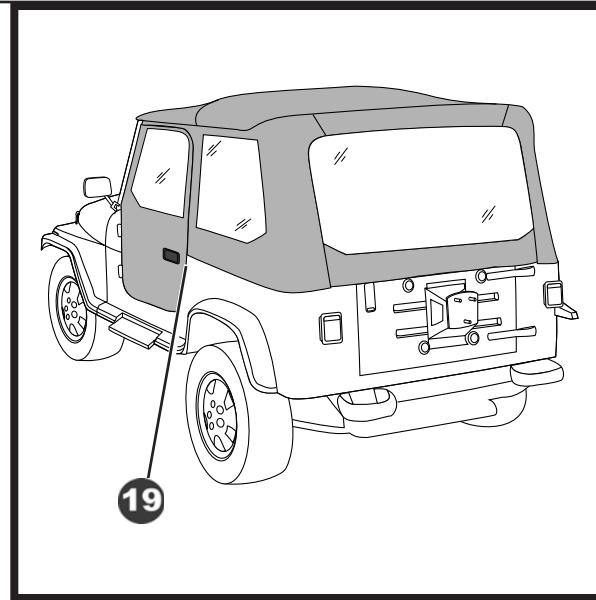
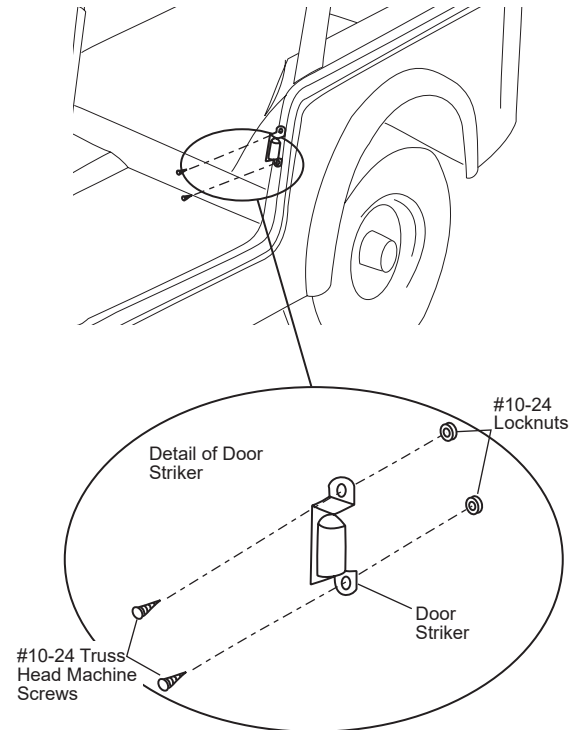

Tigertop™ – Installation Instructions



WARNING

When operating the vehicle with the rear window open, one or more door windows should be open for proper ventilation.

20 Adjusting the Top

Rear Curtain

To roll up the Rear Curtain, start at the bottom and roll it to the inside. Avoid wrinkles in the fabric and window. Secure it in place with the curtain straps inside of the top.

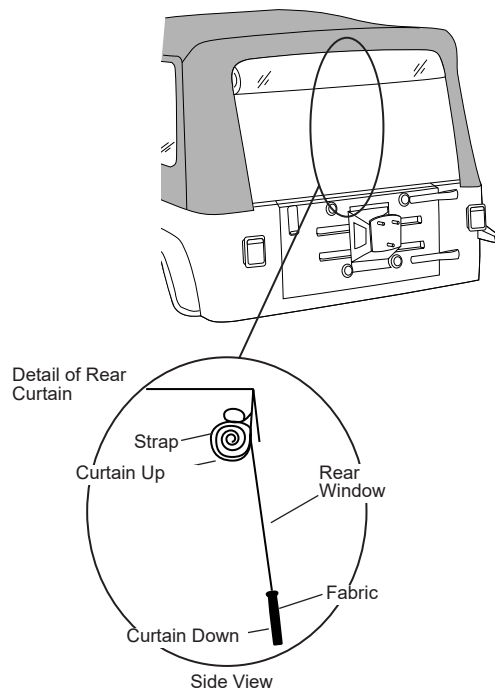

21 Folding the Top Down

Unsnap the Rear and Side Curtains and open the Rear Curtain zippers. Fold the Side Curtains up onto the top and release the hook and loop fasteners on the flaps, above the doors. Unsnap the top from the rear bow.

Release the locking tabs on the Bow Releases from the holes in the bow and slide the rear bow down to the Bow Mounts. Release the Horizontal Rod from the Front Rod Retainers. Remove the Vertical Rod from the Vertical Retainer Mount and lay the bow assembly down on the rear of the vehicle.

Unfasten the top from the windshield and lay it down on the body. Make sure that the rear corners of the top are tucked under the rear bow. Fold the top in half from front to back and continue folding until the top is about 1 foot wide at the rear of the vehicle. Secure the Vertical Retainers and the Horizontal Rods by clipping them into the Rod Retainers on the Bow Mounts. Secure the rear of the bow assemblies by snapping the Bow Tie Down Straps to a Corner Body Stud.

22 Removal of Soft Top for Open Air Driving

When operating the vehicle with the fabric top removed, it is very important that the supporting hardware system be disconnected from the windshield bracket and folded flat to the rear of the vehicle. The vertical and horizontal rods should be snapped into the plastic clips located on the inside of both bow mount brackets. Wrap the elastic straps around the bows and snap them to the body studs. Never operate the vehicle with the fabric removed and the hardware in the fully erected position.

Tigertop™ – Installation Instructions

Care and Maintenance of your Bestop Product

Your Bestop product is made of the finest materials available. To keep it looking new and for the maximum possible wear, it will need periodic cleaning and maintenance.

Washing: The fabric should be washed often using soap, warm water and a soft bristle brush. Rinse with clear water to remove all traces of soap or use Bestop-recommended Bestop Cleaner and Bestop Protectant. Bestop Cleaner and Bestop Protectant are specially formulated to provide a total cleaning and protection system. Bestop Cleaner will not harm vehicle finish, is biodegradable and environmentally friendly. Bestop Protectant protects against UV-fading, cracking and hardening.

Windows: Keep windows clean to avoid scratching. DO NOT use a brush on the windows! Wash with a water-soaked cloth or sponge and a mild dishwashing detergent or use Bestop-recommended Bestop Vinyl Window Cleaner, which safely cleans and protects vinyl windows while helping prevent UV damage. NEVER WIPE THE WINDOWS WHEN THEY ARE DRY. Be careful when cleaning snow or frost from the vinyl windows since they are easily scratched and may crack at low temperatures. DO NOT roll the sides or rear window in cold weather. The windows become stiff and will crack.

Zippers: Keeping the zipper cleaned and lubricated with a silicone lubricant will help prevent damage and keep the zippers in a smooth working condition. If a zipper opens behind the slider, the slider may have been spread apart. This problem can usually be repaired by using an ordinary pair of pliers to bring the sides back into parallel. Return slider to the end of the zipper in the normal Open position. Squeeze lightly at first and test the zipper. If the zipper continues to remain open squeeze more firmly with the pliers and try the zipper again. Repeat this procedure until the zipper operates correctly.

Water: Seeping through at the seams may be stopped by applying 3-M Scotchgard® on the inside of the seams. Rips in the fabric may be repaired with Bondex® iron on patches. Iron the patches to the Inside of the top, carefully following the Bondex® instructions.

Snaps: Keep snaps cleaned and lubricated with silicone to help prevent snaps from sticking to the studs. If a snap does become stuck to a stud, use a screwdriver and GENTLY pry apart to prevent permanent damage to the snap or the top fabric.

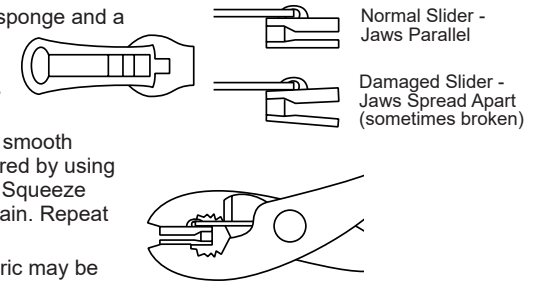

LIMITED WARRANTY

We warrant our product to be free from defects in material and workmanship, for the terms specified below, provided there has been normal use and proper maintenance. This warranty applies to the original purchaser only. All remedies under this warranty are limited to the repair or replacement of any item or items found by the factory to be defective within the time period specified. If you have a warranty claim, first you must call our factory at the number below for instructions. You must retain proof of purchase and submit a copy with any items returned for warranty work. Upon completion of warranty work, if any, we will return the repaired or replaced item or items to you freight prepaid. Damage to our products caused by accidents, fire, vandalism, negligence, misinstallation, misuse, Acts of God, or by defective parts not manufactured by us, is not covered under this warranty.

THE WARRANTY TIME PERIOD IS AS FOLLOWS FOR REPLACE-A-TOP™, SAILCLOTH REPLACE-A-TOP™, SUPERTOP®, SUPERTOP® REPLACEMENT SKINS, SUNRIDER®, AND TIGERTOP®: TWO YEARS FROM DATE OF PURCHASE.

THE WARRANTY TIME PERIOD IS AS FOLLOWS FOR ALL OTHER "SOFT GOODS" MANUFACTURED BY OUR COMPANY (USING PRIMARILY VINYL, PLASTICS, AND/OR FOAM): ONE YEAR FROM DATE OF PURCHASE.

THE WARRANTY TIME PERIOD IS AS FOLLOWS FOR ALL OTHER "HARD GOODS" MANUFACTURED BY OUR COMPANY (USING PRIMARILY METALS, PLASTICS, AND/OR FIBERGLASS): ONE YEAR FROM DATE OF PURCHASE.

ANY IMPLIED WARRANTIES OF MERCHANTABILITY AND/OR FITNESS FOR A PARTICULAR PURPOSE CREATED HEREBY ARE LIMITED IN DURATION TO THE SAME DURATION AND SCOPE AS THE EXPRESS WRITTEN WARRANTY. OUR COMPANY SHALL NOT BE LIABLE FOR ANY INCIDENTAL OR CONSEQUENTIAL DAMAGE.

Some states do not allow limitations on how long an implied warranty lasts, or the exclusion or limitation of incidental or consequential damages, so the above limitations or exclusions may not apply to you. This warranty gives you specific legal rights, and you may also have other rights which vary from state to state.



For further information or request for warranty work, please contact:

Bestop Inc., Customer Service
Toll-Free: (800)845-3567
Main: (303)465-1755
E-mail: csbestop@Bestop.com
Website: www.Bestop.com