



by 

# Tiger Top

**Installation Instructions and Owner's Manual**

**Model: CJ2A, 1946-1948 & MB, 1941-1945**

**Part Number 51402**

Congratulations on your purchasing decision. Bestop designed this Convertible Top to give you years of dependability and performance with proper care. If you encounter any problems during the installation of your Convertible Top, or at any later date, please contact your authorized Bestop dealer or call our Consumer Response Department, Monday - Friday 8AM-4:30PM (MST) at 1-800-346-3910 or (303) 465-1755 in Colorado.

**Note: Please read this manual thoroughly before beginning the installation. After completing installation, keep this manual for future reference.**

**Fig. 1 CJ2A, 1946-1948 A: 25"**  
**MB, 1941-1945 A: 23"**

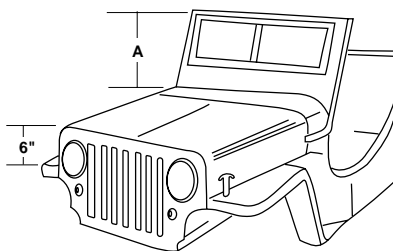

**Fig. 2 CJ3A, 1949-1953**  
**M38, 1950-1951**

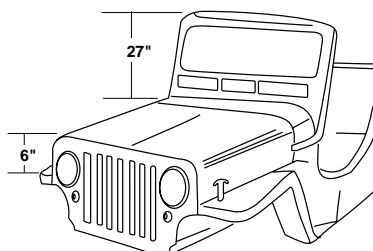

**Fig. 3 CJ3B, 1953-1964**

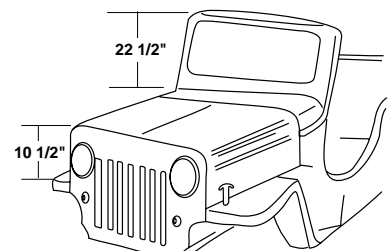

Windshields are sometimes interchanged on older model vehicles. The vehicle's windshield and body style are the key factors that determine which convertible top model number fits a particular vehicle. These diagrams will help you identify your vehicle to determine which top you need.

**Fig. 1 & 2** These models have interchangeable windshields. Regardless of vehicle model number, style of windshield determines which top will fit the vehicle.

CJ2A and MB models have a windshield frame of round tubular steel. Frame corners are square, glass is in two pieces.

CJ3A and M38 models have a frame made of rectangular steel tubing with rounded corners and a one piece windshield glass.

**Fig. 3** The CJ3B has a higher hood than older models. The windshield is made of rectangular steel tubing with one piece glass.

### **Warning:**

**This product is designed primarily to enhance the appearance of the vehicle. Do not rely in any way on the components of this product to contain occupants within the vehicle, or to protect against injury or death in the event of an accident. This top will not protect the occupants from falling objects. Never operate vehicle in excess of manufacturer's specifications.**

**WEAR SEAT BELTS AT ALL TIMES**

**Read and follow, precisely, all installation instructions provided when installing top. Failure to do so may result in a poor fitting top and could place occupants of the vehicle in a potentially dangerous situation.**

## ***Before You Install***

You may notice some wrinkling in the fabric of your Convertible Top when you first remove it from its shipping container. Also, there may be indentations in the windows. **Don't Panic.** It is normal for the tops to do this when stored in the shipping container. The wrinkles and indentations will disappear after 48-72 hours of exposure to sunlight.

**Note:** *You should install your Convertible Top in temperatures of 70° F (21° C) or warmer. The fabric will contract in cooler temperatures, making proper installation difficult.*

You are now ready to begin the installation process.

## **Installation: Getting Started**

**Note:** *Two people are required for installation.*

Make sure that the temperature where you are going to install your Convertible Top is at least 70° F (21° C). If it is cooler than this outside, we suggest that you install your top in a heated garage. Do not try to install your Convertible Top in temperatures less than 70° F (21° C) because proper installation will not be possible.

## **Tools You Will Need**

- |  |   |
|--|---|
| <input type="checkbox"/> A flat head screwdriver   | <input type="checkbox"/> An adjustable wrench |
| <input type="checkbox"/> A phillips head screwdriver   | <input type="checkbox"/> A hammer             |
| <input type="checkbox"/> A tape measure  | <input type="checkbox"/> A center punch       |
| <input type="checkbox"/> 1 ea. 3/32", 1/8", 5/32", 3/16" and 3/8" drill bits and a power drill | <input type="checkbox"/> A pencil             |
|  | <input type="checkbox"/> A piece of chalk     |

## **Unpacking: What You Have**

### ***Important - Please Read***

*Even though Bestop has taken every possible precaution to include all the parts necessary to install your Convertible Top, sometimes pieces are unintentionally left out. DO NOT RETURN YOUR CONVERTIBLE TOP. Immediately contact Bestop at 1(800)346-3910 or, in Colorado, at (303)465-1755. We will then be able to forward the necessary part to you or have you contact a local distributor to ensure the most expedient service.*

Carefully remove the parts from the shipping container to avoid scratching the windows. Check each part against the following Parts List.

**USE ONLY PARTS THAT COME WITH THIS TOP, SINCE OLD PARTS MAY NOT MATCH.**

# Parts List and Hardware Identification

Check off each item

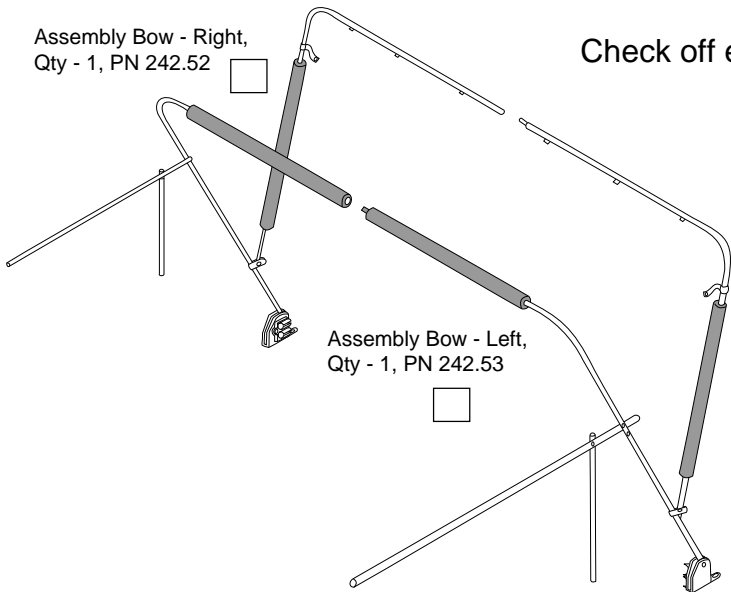



 10 x 1/2" Small Pan Head Phillips Screw, Qty - 10, PN 1.92

 5/16-18 x 1" Phillips Machine Screw, Qty - 4, PN 236.20

 Threaded Body Stud, Qty - 4, PN 151.81

 #10 x 1/2" Oval Head Phillips Screw, Qty - 4, PN 155.49

 #14 Sheet Metal Screw, Qty - 8, PN 243.47

 Vertical Rod Bracket - Right, Qty - 1, PN 229.24

 Vertical Rod Bracket - Left, Qty - 1, PN 229.25

 #8 x 1/2" Self-tapping Phillips Washer Screw - Black, Qty - 12, PN 200.48

 #6 Sheet Metal Screw, Qty - 24, PN 9.69

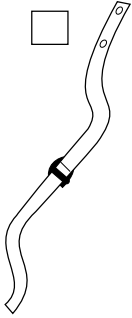
 Buckle Strap Assembly, Qty - 2, PN 243.61



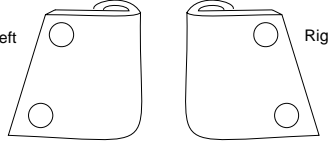

 5/16" Black Washer, Qty - 4, PN 233.04

 Upper Left & Right Door Hinges, Qty - 1 ea., PN 1.37 & 1.36

 Body Stud, Qty - 24, PN 9.68

 #10-32 Hex Nut, Qty - 4, PN 151.82

**Handle Kit, Packaged together, PN 185.23**

			
Inside Door Handle, Qty - 1 Left, 1 Right	Outside Door Handle, Qty - 2	Plastic Handle Covers, Qty - 2 each 2 1/2" long, 2 each 3 3/8" long	7/16" Plastic Washer, Qty - 4

 5/16-18 Tapped Plate, Qty - 4, PN 200.50

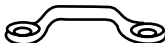
 Black Footman Loop, Qty - 2, PN 272.29

**Windshield Riser Kit - MB, 1941 - 1945 Only**

Riser,	Qty - 1,	PN 2.40	<input type="checkbox"/>
Rubber Grommet,	Qty - 2,	PN 11.20	<input type="checkbox"/>

 #10 x 1/2" Small Pan Head Phillips Screw, Qty - 10, PN 1.92

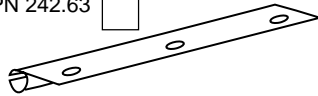
 Retainer Door Windshield Assembly, Qty - 4, PN 242.63

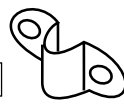
 Lower Door Hinge, Qty - 2, PN 12.41

Top Fabric Qty - 1  
 Door - Right Qty - 1  
 Door - Left Qty - 1

Because of Generic Packaging, extra parts may be included.

# Installing your Convertible Top

Regardless of what type of hardware you currently have on your vehicle, it is extremely important that you only use the hardware found in this Convertible Top kit. This Convertible Top cannot be used with your existing hardware.

## Windshield Adjustment

This is the first step you must take in the installation process and it is also the most important one. Improper windshield adjustment results in poor fitting of both the top and the doors, as well as misalignment of snaps.

### Step One

Measure and record the distance from the top inside edge of the windshield to the rear inside edge of the vehicle body (see Figure 1), **not the tailgate**. Take the measurement from approximately six inches inside the vehicle's doors. Check to make sure that both sides measure equally. To install this top properly, this measurement must be **66 1/2 inches (CJ2A)** or **65 1/2 inches (MB)**.

Figure 1

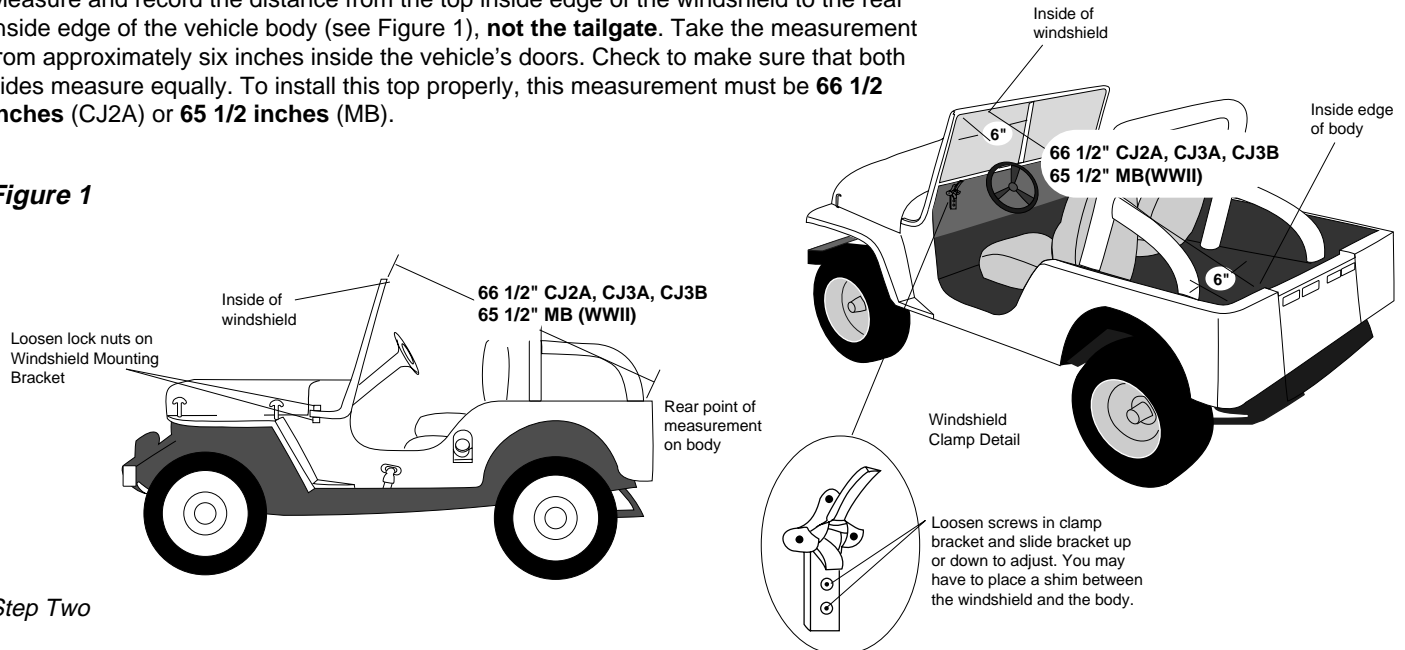

### Step Two

If necessary, adjust your windshield by loosening the screws in the Windshield Mounting Bracket and by loosening the Windshield Clamps and adjusting the clamp bracket (see Figure 1). You may then lean the windshield forward or back as necessary. Use a shim to fix the windshield in place if it remains loose after you tighten the screws.

**Note:** The CJ2A has no existing Windshield Mounting Bracket. To adjust the windshield, loosen the Windshield Clamps, bend the arms and retighten the clamps.

## The Mounting Assembly

This section will lead you through the installation of the various pieces that make up your Convertible Top hardware system.

### Vertical Retainer Mounts

**CAUTION:** Installation of the Vertical Retainer Mounts involves drilling in the top edge of the vehicle body. Check under the body edge at the marked locations. There may be wiring for the rear lights. If so, pull the wiring out of the way before drilling.

### Step One

Measure 33 1/2 inches and 34 1/2 inches along the top edge of the body from the outside rear of the body (see Figure 2). Mark these locations with a pencil on the top edge of the body. Center punch the marked locations and drill a 3/8 inch hole at each location (see Figure 2). Install the mounts using two 5/16-18 x 1" Phillips Head Bolts, two Washers and two 5/16-18 Tapped Plates. Repeat this procedure on the opposite side of the vehicle. The mounts may need to be loosened later to adjust the Vertical Retainer position.

**Figure 2**

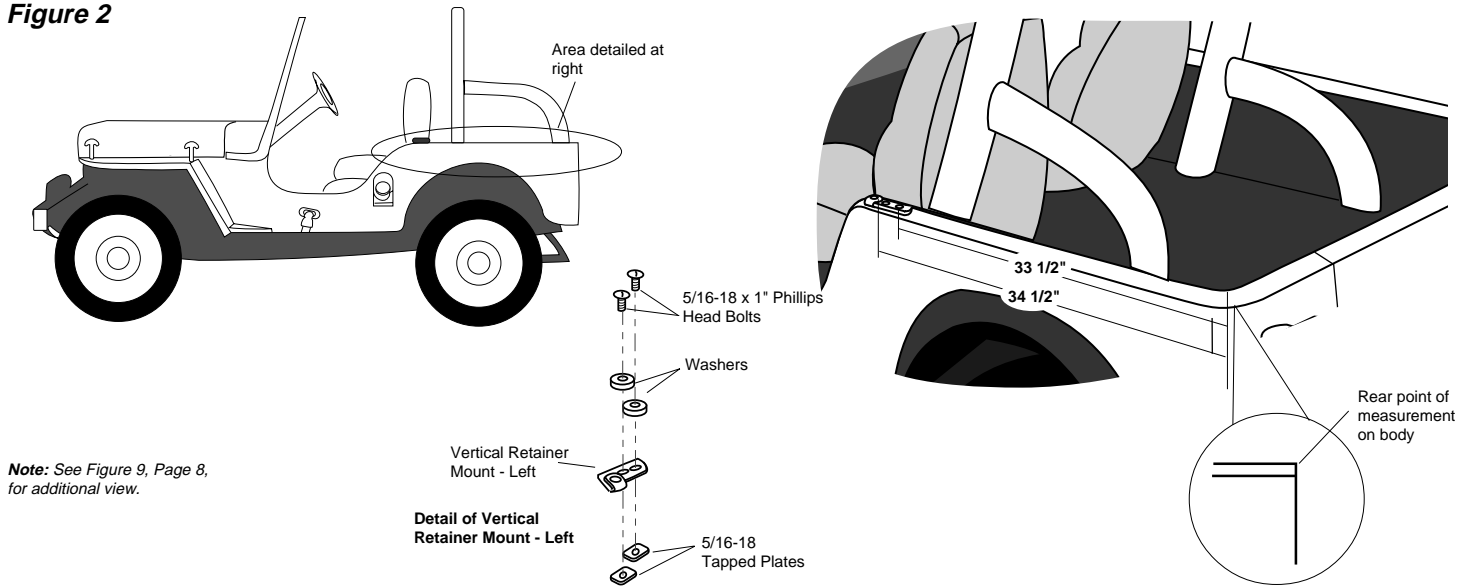

## Bow Assembly

**CAUTION:** Installation of the Bow Assemblies involves drilling in the top edge of the vehicle body. Check under the body edge at the marked locations. There may be wiring for the rear lights. If so, pull the wiring out of the way before drilling.

### Step One

Measure 27 3/4 inches and 29 3/4 inches along the top edge of the vehicle from the outside rear of the body (see Figure 3). Mark the locations with a pencil on the top edge of the vehicle. Center punch the locations and drill a 3/16 inch hole at each location. Repeat this procedure on the opposite side of the vehicle.

**Figure 3**

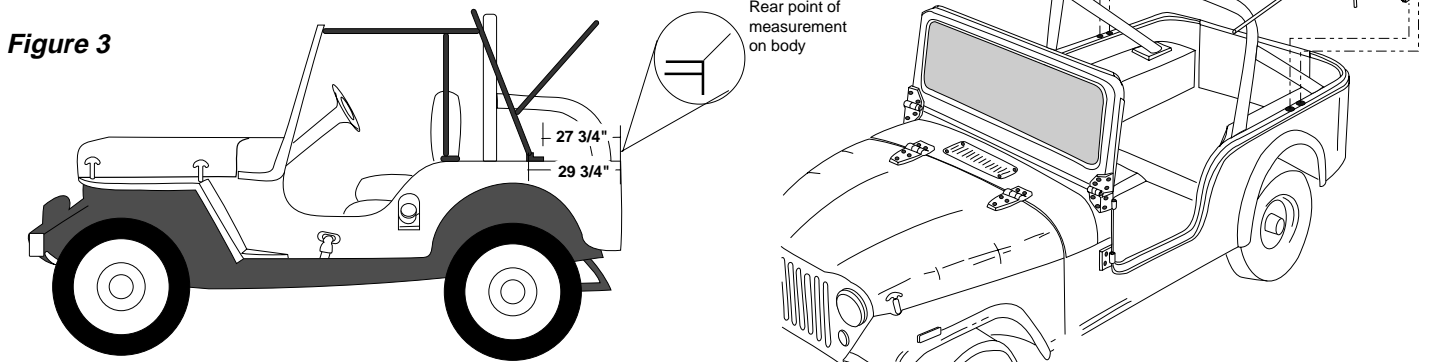

### Step Two

This step will require two people. Locate the left and right Bow Assemblies in the parts kit. Select one of the assemblies and lay the assembly on the body. Secure the front hole of the bow mount bracket with a #14 Sheet Metal Screw. Do not tighten the screw yet. Then secure the front hole of the other bow assembly on the opposite side of the vehicle. Once the brackets are in place, lift up the bow assembly and secure the rear hole of each bow bracket with a #14 Sheet Metal Screw. It will help here if one person steadies the bow assembly while the other person assembles the #14 Sheet Metal Screws to the vehicle. Tighten the screws. Lay the bow assemblies down onto the body and start the male end of one assembly into the female end of the other assembly. Push the bows forward to snap them into place.

## Footman Loops

**CAUTION:** Installation of the Footman Loops involves drilling in the top edge of the vehicle body. Check under the body edge at the marked locations. There may be wiring for the rear lights. If so, pull the wiring out of the way before drilling.

### Step One

Install the Footman Loops on the top rear corners of the vehicle. Use the loops as templates to mark, center punch and drill 5/32 inch holes. Use two #10 x 1/2 Oval Head Phillips Screws to secure the loops in place (see Figure 4).

**Figure 4**

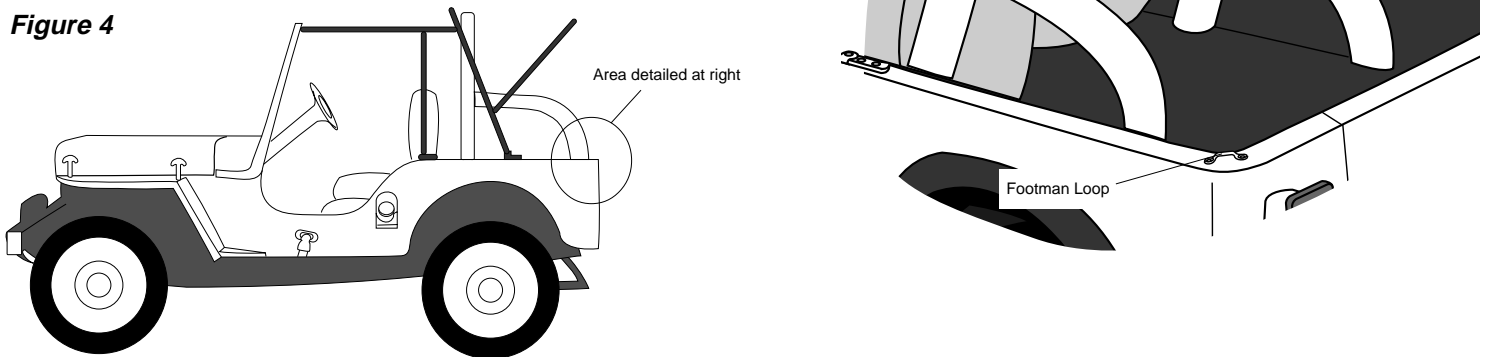

**Important Note:** Before continuing please check the following items.

**Note:** A Windshield Adapter is required to install top on MB, 1941-1945 WWII Military model or CJ2A with low windshield. It has been included in Part # 51402 Soft Top Kits.

**Fig. 1 CJ2A, 1956-1948 A: 25"**  
**MB, 1941-1945 A: 23"**

Windshields are sometimes interchanged on older model vehicles. The vehicle's windshield and body style are the key factors that determine which convertible top model number fits a particular vehicle. These diagrams will help you identify your vehicle to determine which top you need.

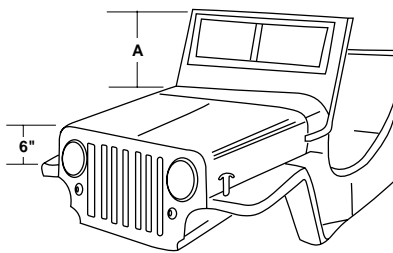

**Fig. 2 CJ3A, 1949-19453**  
**M38, 1950-1951**

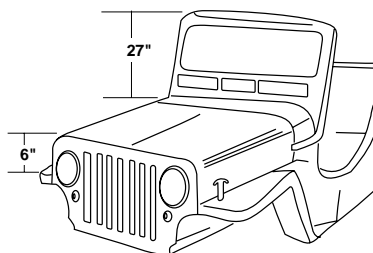

**Fig. 3 CJ3B, 1953-1964**

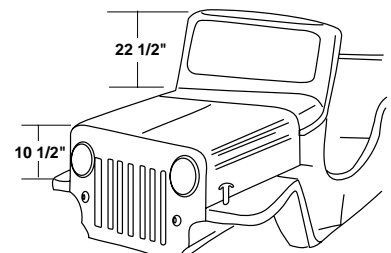

**Fig. 1 & 2** These models have interchangeable windshields. Regardless of vehicle model number, style of windshield determines which top will fit the vehicle.

CJ2A and MB models have a windshield frame of round tubular steel. Frame corners are square, glass is in two pieces.

CJ3A and M38 models have a frame made of rectangular steel tubing with rounded corners and a one piece windshield glass.

**Fig. 3** The CJ3B has a higher hood than older models. The windshield is made of rectangular steel tubing with one piece glass.

## 51402 Windshield Riser

### CJ2A, MB

**Note:** For MB, 1941-1945 models or CJ2A with low windshield, a riser is required to extend the height.

#### Step One

Locate the Riser over the top of the windshield frame as shown in Figure 5. Use the Riser as a template and drill 1/8 inch holes to correspond with the holes in the Riser. Fasten the riser into place using the #10 Sheet Metal Screws.

**Figure 5**

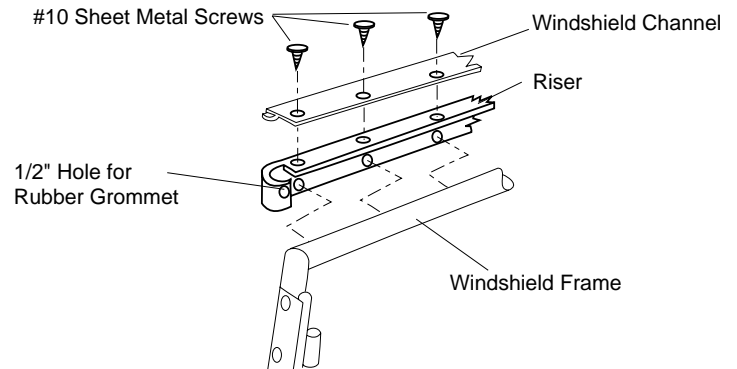
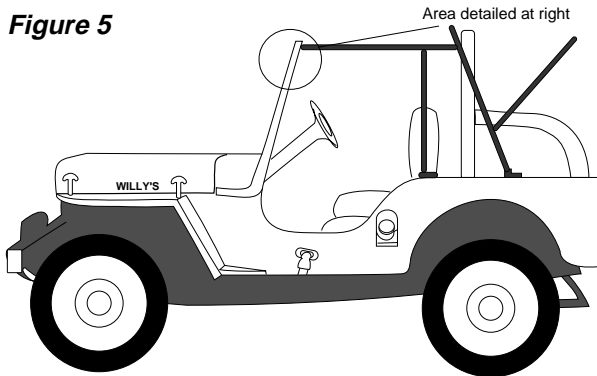

#### Step Two

Insert the two rubber grommets into the 1/2" diameter holes in the Riser (see Figure 5). These holes are for the Horizontal Rods provided with the top.

#### Step Three

Locate the Windshield Channel provided with the top. Place the channel on top of the Riser (see Figures 5 and 6). Use the channel as a template and drill 1/8" holes to correspond with the holes in the Windshield Channel. Fasten the channel into place with the Sheet Metal Screws provided in the Top kit.

**Figure 6**

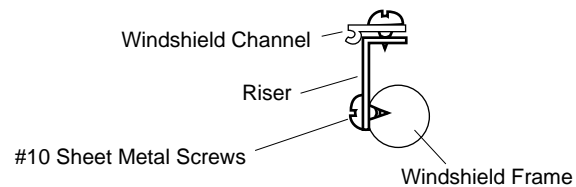
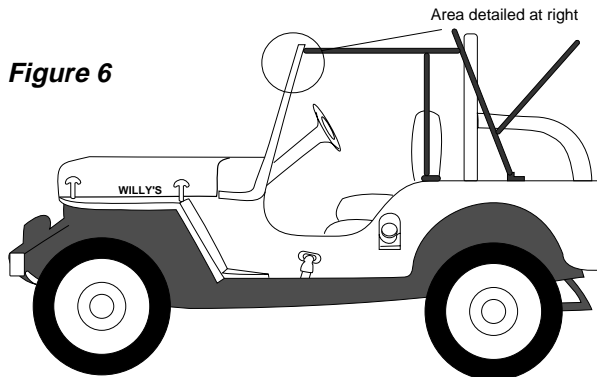

**Note:** The vehicle should measure 66 1/2 inches from the 1/2 inch hole for the rubber grommet to the inside rear of the body. See the **Windshield Adjustment** section of this manual.

#### Step Four

Proceed to the Top Fabric Installation Section.

## Windshield Channels and Upper Door Hinges

### Step One

Drill a 3/8 inch hole in each upper, inside corner of the windshield frame (see Figure 7). Do not drill all the way through the windshield frame. Some vehicles may have a 5/16 inch hole at this location. If so, drill out to 3/8 inch. These holes will be used to secure the Horizontal Rods to the windshield frame.

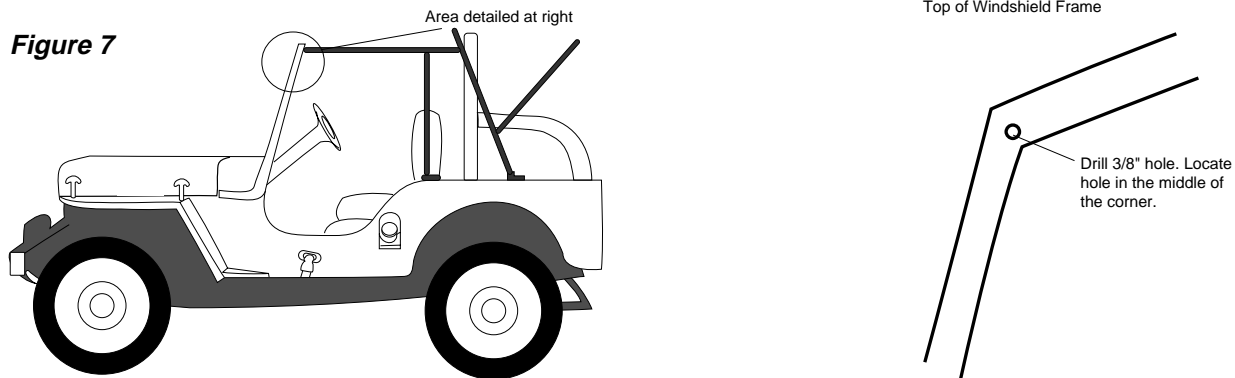

### Step Two

Center the windshield channels on the top of the windshield frame so that the two pieces of channel are flush with each other and butted up against the windshield frame (see Figure 8). Use the channels as templates to mark, center punch and drill with a 1/8 inch drill bit. Secure using #8 x 1/2" Self-tapping Pan Head Washer Screws.

**Caution:** A loose Windshield Retainer may allow the top to disengage from the windshield, causing damage to the top and possible injury to the occupants of the vehicle. Make certain that the Windshield Retainer is securely fastened to the windshield at the time of first installation. Check the tightness of the mounting screws every three months. (Do not over tighten.)

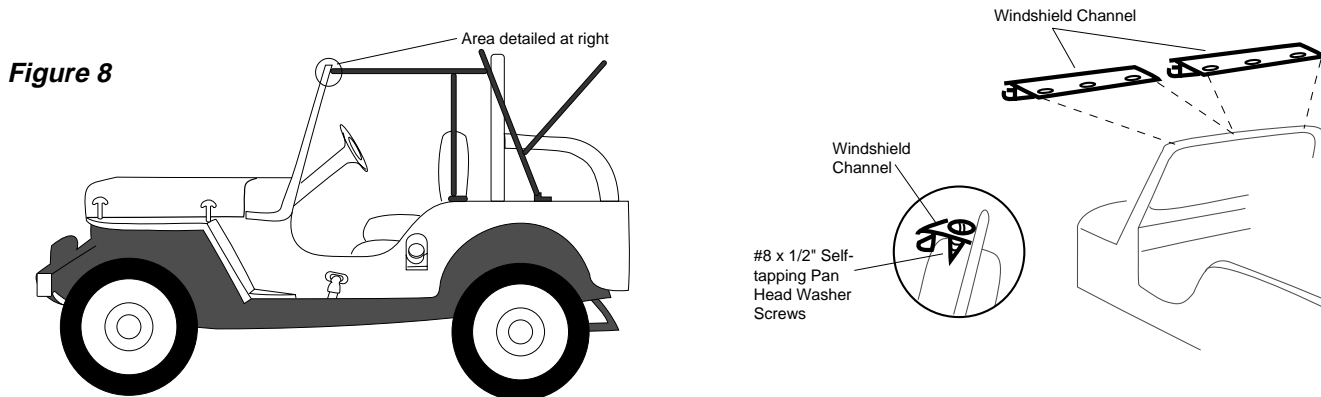

### Step Three

If your vehicle does not have Door Channels, use those provided in the parts kit. Orient the channels with the "tails" down and install them on the outside of the windshield frame, in the existing holes, using four #10 Sheet Metal Screws on each side (see Figure 9).

### Step Four

Locate the upper door hinges 3 inches below the hole that was drilled for the Horizontal Rods (see Figure 9). Use the hinges as templates to mark, center punch and drill 3/16 inch holes. Secure using #14 x 1/2" Pan Head Screws.

**Figure 9**

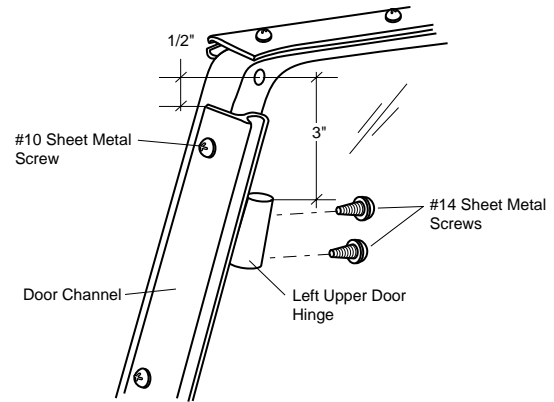
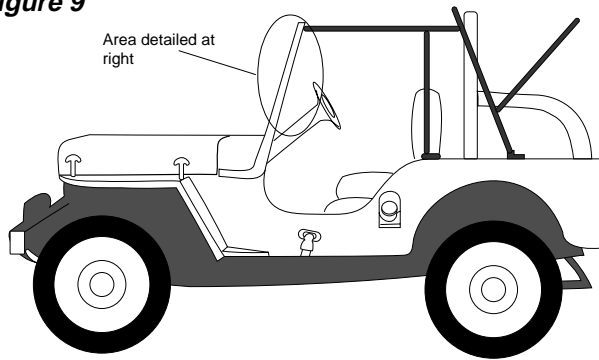

## Top Fabric Installation

This section will require two people.

### Step One

Rotate the front bow assembly forward and insert the Vertical Rods into the Vertical Retainer Mounts (see Figure 10). Insert the Horizontal Rod into the hole in the windshield.

**Figure 10**

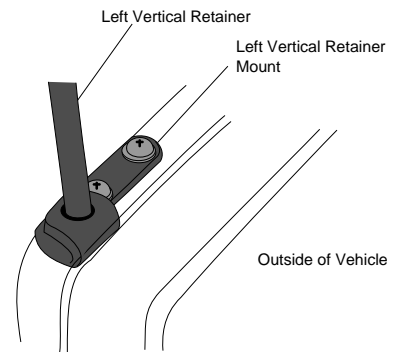
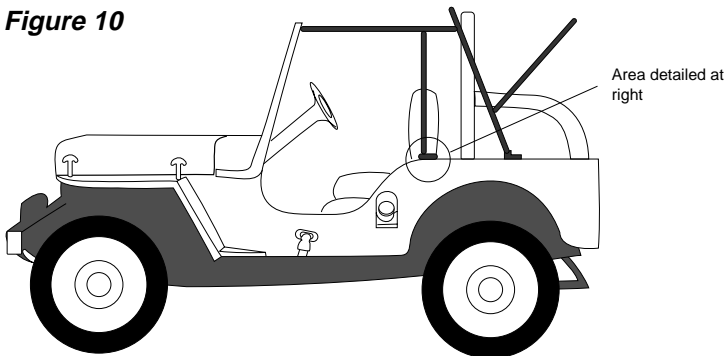

Left Side of Vehicle Shown

### Step Two

Unfold the top and drape it over the front bow. Insert the front strip into the existing windshield channel on the front of the windshield frame. Make sure that the fabric is centered on the windshield. **Failure to center the fabric could result in torn fabric.**

### Step Three

Lift the Rear Bow and drape the top over it. Snap the flaps on the inside of the top to the studs on the Rear Bow. Locate the Buckle Straps in the parts kit. Wrap each strap around the corners of the Rear Bow and snap the straps to themselves. This strap will hold down the Rear Bow when the Rear Curtain and Side Panels are rolled up.

## Installing the Body Studs

The following steps are crucial to the proper installation of the top. This step will require two people. Make sure that the top fabric is as warm as possible before beginning.

### Step One

Close the zippers on the Rear Curtain. Locate the four holes grouped together on each Front Bow. These holes adjust the tightness of the top. Slide the Rear Bow Assembly and the bow release (both sides) up on the Front Bow Assembly and slip the small, bent tab of the bow release into the bottom hole on the Front Bow.

### Step Two

Rub chalk on the snaps on the inside of the top to mark the stud locations.

### Step Three

Start at the tailgate and install four (4) Threaded Body Studs in the existing holes, as shown in Figure 11. Secure the studs with Hex Nuts and snap the rear curtain down to them.

### Step Four

To ensure a good fit, have one person pull down on the rear bow while the other person pulls the fabric down and to the rear to locate the rear corner studs. When you are satisfied with the tightness of the top, press the snaps against the body. The chalk will leave marks for the Body Stud locations. (The Body Studs should be 3/4 inch below the top of the body.) Center punch the marks and drill 3/32 inch holes at the marked locations on each rear corner. Install a Body Stud and #6 x 3/8 Sheet Metal Screw in the rear corners. Snap the top to the corner body studs.

### Step Five

Slide the Rear Bow Assembly and bow release up to the third hole from the bottom on both Front Bow assemblies. Move to the front of one of the side panels. Pull the top fabric down and forward to eliminate wrinkles and to ensure a proper fit. Install a Body Stud and a #6 x 3/8 Sheet Metal Screw. Repeat this procedure on the opposite side of the vehicle. Snap the top to each new stud.

### Step Six

Install the remaining studs on the Side Panels. **Alternate from side to side as you install the studs** and snap the top to each new stud. This will keep the tension of the top evenly spread.

**Figure 11**

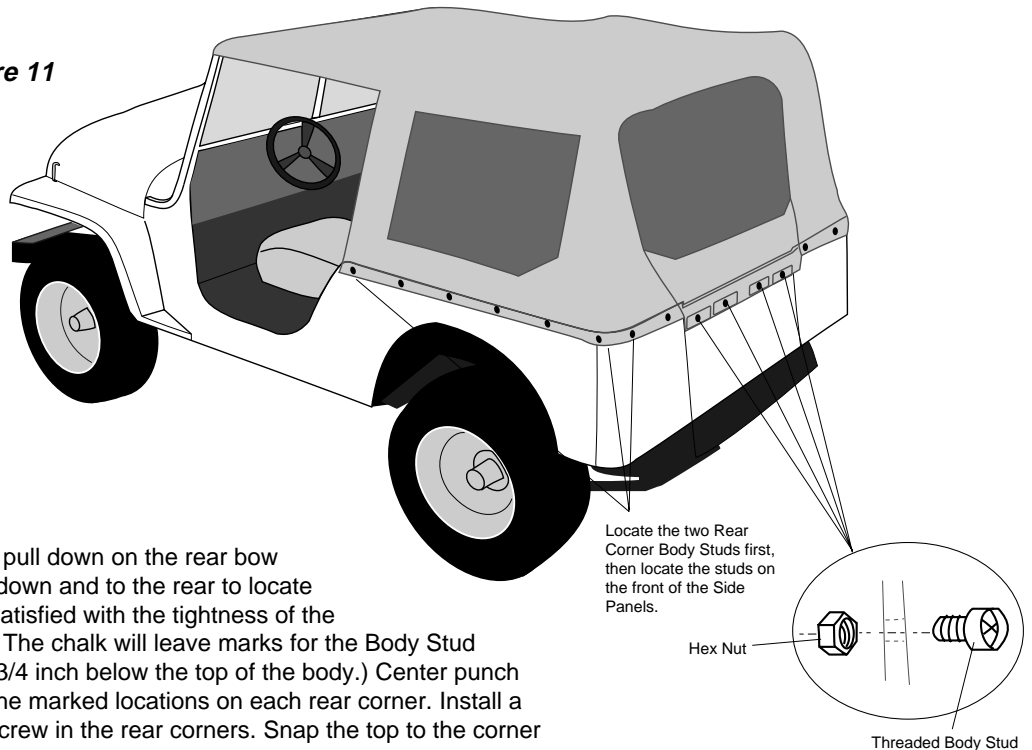

### Step Seven

Thread the buckle strap assembly through each Footman Loop and then back through the buckle. Do not over tighten. Wrap the fabric flaps, sewn to the top above and behind the doors, around the horizontal rods and vertical retainers and fasten the hook and loop fasteners. Fasten the hook and loop fasteners around the Front Bows. (The Vertical Retainer Mounts may be adjusted forward or backward if needed.)

### Step Eight CJ2A

There is a snap on each front corner of the top fabric. Pull the fabric forward and down to eliminate wrinkles. Mark the locations for the Body Studs. Center punch and drill 3/32 inch holes. Install the Body Studs with #6 x 3/8 inch Sheet Metal Screws. Make sure that the fabric is centered on the windshield. **Failure to center the fabric could result in torn fabric.**

---

## Adjusting the Top

### Rear Curtain

To roll up the Rear Curtain, start at the bottom and roll it to the inside. Avoid wrinkles in the fabric and window. Secure it in place with the curtain strap inside of the top (see Figure 12).

Figure 12

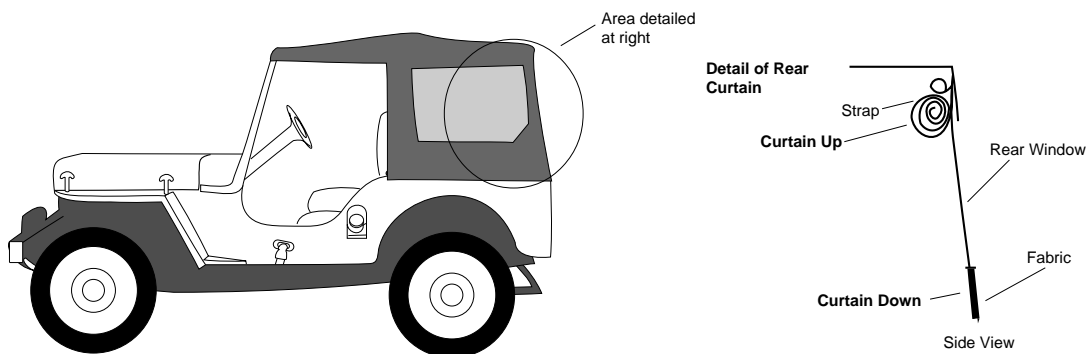

### Side Curtains

To roll up the Side Curtains, fold the bottom rear corner of the panel forward and roll the curtain to the outside. Avoid wrinkles in the fabric and the windows. Secure the curtain in place with the curtain straps inside the top (see Figure 13).

Figure 13

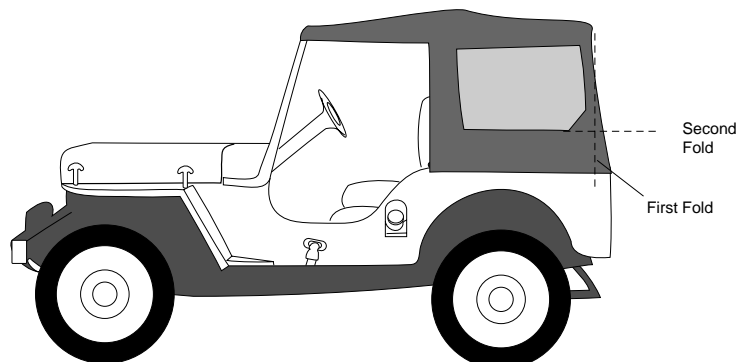

## Door Installation

**Warning:** The doors in this product are designed only for protection against the elements. Do not rely on the doors to contain occupants within the vehicle or to protect against injury during an accident. Door handles are only designed to aid in door closure. Door and handle will not support a person's weight.

Assemble the Door Handles by:

- a. Installing a flat washer over the square peg on the inside handle.
- b. Installing the inside handle through the handle mount. The long ear points up and the short ear points to the rear of the door.
- c. Installing a flat washer over the square peg on the outside of the door fabric.
- d. Installing the outside handle onto the square peg. Squeeze the inside handle and outside handle together and tighten the set screws on the outside handle (see Figure 14). (The outside handle should point to the rear of the door in the closed position.)

**Note:** A small amount of glue on the ears of the inside handle will prevent loss of the handle covers.

**Figure 14**

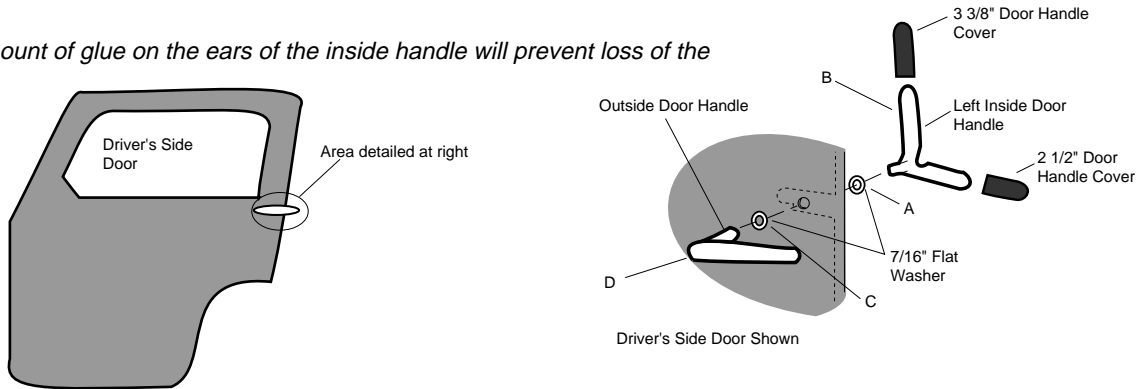

## Lower Door Hinge Installation

### Step One

Unzip the door window. Roll tightly to the inside of the door and secure with the elastic strap. Hold the top of the door at a 90 degree angle to the body and start the top, front flange of the door fabric into the bottom of the windshield door channel. Slide the door fabric up into the door channel until the upper door pivot is just below the upper hinge on the windshield. Work the upper door pivot into the upper hinge (see Figure 15). (**Note: CJ2A - The top of the door will close on the Horizontal Rod or may be set to close just below the Horizontal Rod.**) Hold the door in the closed position. Latching the door with the inside handle will assist in locating the proper door position. Tension of the door may be adjusted by bending the inside handle. Visually inspect the inside and outside of the door for proper fit.

**Figure 15**

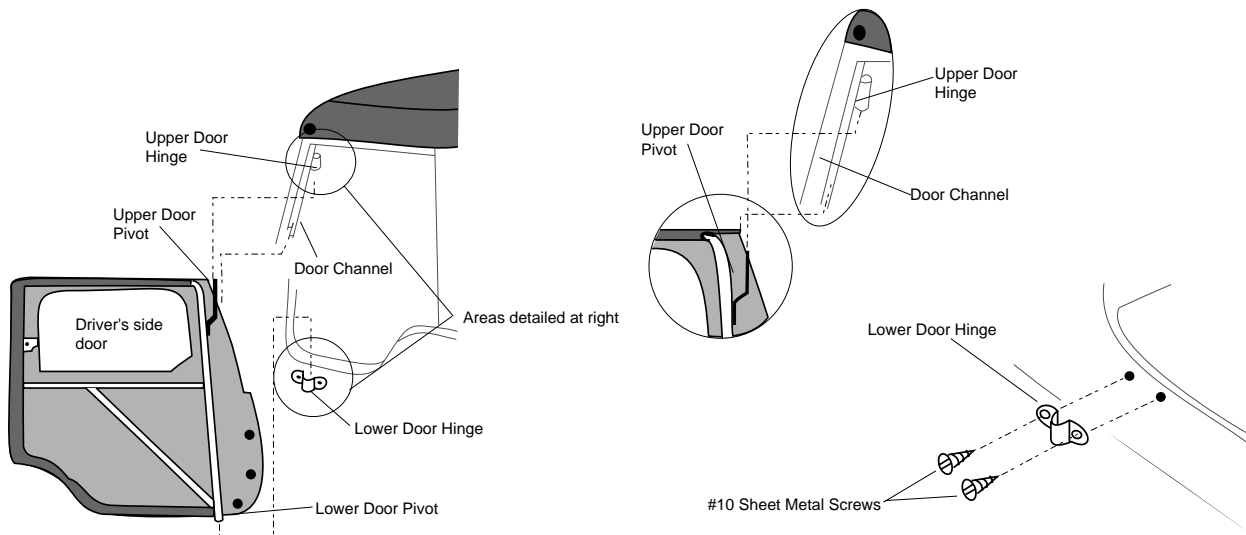

**Note:** After installation of the door, the frame of the door may be bent slightly to fit the contour of the vehicle body.

### Step Two

Once the door is in position, mark the location for the Lower Door Hinge. Center punch and drill two 5/32 inch holes. Secure the Lower Door Hinge using two #10 x 1/2" Pan Head Sheet Metal Screws (see Figure 15).

### Step Three

For best results, the window should be zipped closed for this step.

Install the body studs by marking the snaps on the door fabric with chalk, holding the door open 12 inches and pulling the fabric forward. **Note:** Do not hold the door open more than 15 inches when installing the body studs. Fabric may tear or the snaps may pull out of the door fabric when the door is closed. Press the snaps against the body. The chalk will leave marks for the body stud locations. Center punch and drill 3/32 inch holes at the marked locations. Install a body stud with a #6 x 3/8" Sheet Metal Screw.

Repeat these steps for the other door.

---

## Folding the Top Down

### Step One

Unsnap the Rear and Side Curtains and unzip the Rear Curtain zippers. Fold the Side Curtains along the seam and up over the top. Fold the Rear Curtain up over the Side Curtains. Unfasten the hook and loop fasteners around the Vertical Retainer and the Horizontal Rod. Release the locking tabs on the bow releases from the holes in the Front Bow and slide the Rear Bow down to the Bow Mounts. Insert the bow release tab into the hole on the Front Bow, just above the Bow Mount. Remove the Vertical Retainer and the Horizontal Rod from their mounts and pivot the Front Bow to the rear of the vehicle until it makes contact with the Rear Bow (see Figure 16).

Figure 16

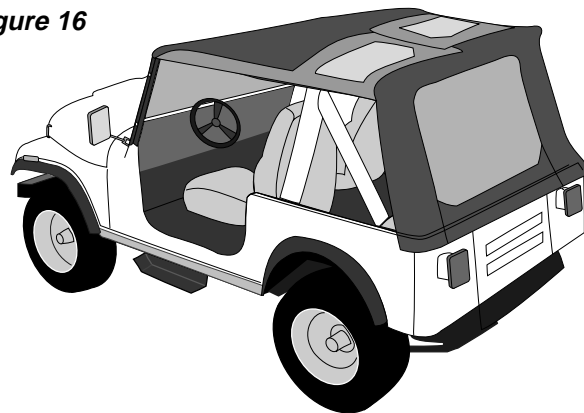

### Step Two

Unfasten the top from the Windshield Retainer and lay the top down on the body (see Figure 17). Fold the top in half from front to back and continue folding until the top is about one foot wide at the rear of the vehicle (see Figure 18). The Buckle Strap assemblies may be used to secure the top to the bow assembly.

Figure 17

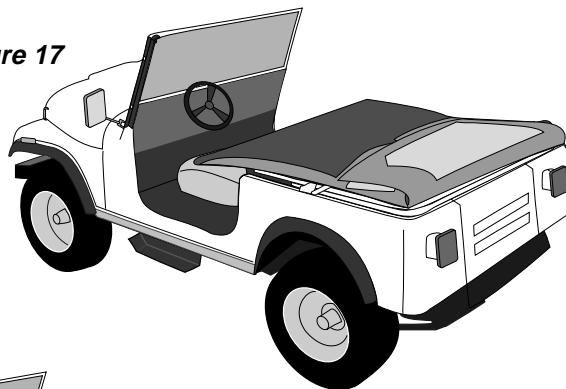

### Step Three

Secure the Vertical Retainers and the Horizontal Rods by snapping each of the Bow Tie Down Straps to a body stud.

Figure 18

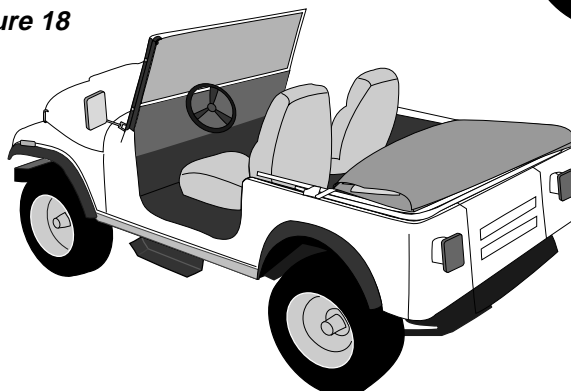

## Care and Maintenance of your Bestop Top

Your top is made of the finest materials available. To keep it looking new and for the maximum possible wear, it will need periodic cleaning and maintenance.

**Washing:** The top fabric should be washed often using soap, warm water and a soft bristle brush. Rinse with clear water to remove all traces of soap.

**Windows:** Keep windows clean to avoid scratching. DO NOT use a brush on the windows! Wash with a watersoaked cloth or sponge and a mild dishwashing detergent. NEVER WIPE THE WINDOWS WHEN THEY ARE DRY. Be careful when cleaning snow or frost from the vinyl windows since they are easily scratched and may crack at low temperatures. DO NOT roll the sides or rear curtain in cold weather. The windows become stiff and will crack.

**Zippers:** Keeping the zipper cleaned and lubricated with a silicone lubricant will help prevent damage and keep the zippers in a smooth working condition. If a zipper opens behind the slider, the slider may have been spread apart. This problem can usually be repaired by using an ordinary pair of pliers to bring the sides back into parallel. Return slider to the end of the zipper in the normal open position. Squeeze lightly at first and test the zipper. If the zipper continues to remain open, squeeze more firmly with the pliers and try the zipper again. Repeat this procedure until the zipper operates correctly.

**Water:** Seeping through at the seams may be stopped by applying 3-M Scotchgard® on the inside of the seams. Rips in the fabric may be repaired with Bondex® iron on patches. Iron the patches to the inside of the top, carefully following the Bondex® instructions.

**Snaps:** Keep snaps cleaned and lubricated with silicone to help prevent snaps from sticking to the studs. If a snap does become stuck to a stud, use a screwdriver and GENTLY pry apart to prevent permanent damage to the snap or the top fabric.

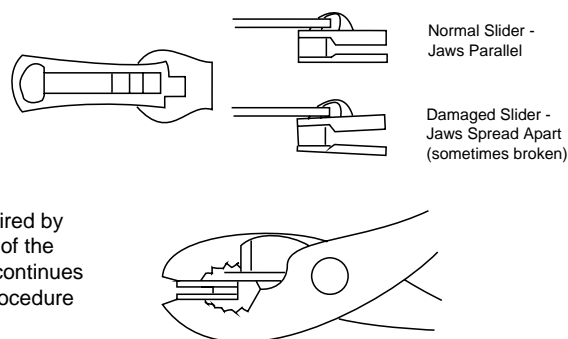

### LIMITED WARRANTY

We warrant our product to be free from defects in material and workmanship, for the terms specified below, provided there has been normal use and proper maintenance. This warranty applies to the original purchaser only. All remedies under this warranty are limited to the repair or replacement of any item or items found by the factory to be defective within the time period specified.

If you have a warranty claim, first you must call our factory at the number below for instructions. You must retain proof of purchase and submit a copy with any items returned for warranty work. Upon completion of warranty work, if any, we will return the repaired or replaced item or items to you freight prepaid. Damage to our products caused by accidents, fire, vandalism, negligence, misinstallation, misuse, Acts of God, or by defective parts not manufactured by us, is not covered under this warranty.

THE WARRANTY TIME PERIOD IS AS FOLLOWS: ALL "SOFT GOODS" MANUFACTURED BY OUR COMPANY (USING PRIMARILY VINYL, PLASTICS, AND/OR FOAM): ONE YEAR FROM DATE OF PURCHASE.

ANY IMPLIED WARRANTIES OF MERCHANTABILITY AND/OR FITNESS FOR A PARTICULAR PURPOSE CREATED HEREBY ARE LIMITED IN DURATION TO THE SAME DURATION AND SCOPE AS THE EXPRESS WRITTEN WARRANTY. OUR COMPANY SHALL NOT BE LIABLE FOR ANY INCIDENTAL OR CONSEQUENTIAL DAMAGE.

Some states do not allow limitations on how long an implied warranty lasts, or the exclusion or limitation of incidental or consequential damages, so the above limitations or exclusions may not apply to you.

This warranty gives you specific legal rights, and you may also have other rights which vary from state to state.

For further information or request for warranty work, please contact:

Bestop Inc.  
Customer Service  
(800)346-3910  
(303)465-1755